



ELEVATE

| CATALOGUE # 08

SOMMARIO INDEX

4 L'AZIENDA THE COMPANY

10 CAVALLETTI MOTO PADDOCK STANDS

- 12 Lego
- 14 Diavol
- 23 Racing
- 25 Off-Road
- 27 Garage and track

31 CARICABATTERIA E AVVIATORI BATTERY CHARGER AND BOOSTER

- 32 Shield LT **NEW**
- 33 Shield 8 **NEW**
- 34 Motorbike battery maintenance station **NEW**
- 35 Shock **NEW**

37 SOLLEVATORI MOTO MOTORCYCLE LIFTS

- 38 Nano
- 41 Nano 600 **NEW**
- 43 Goldrake
- 50 Goldrake ICKS **NEW**
- 52 Customized motorcycle lifts
- 53 Accessories

59 ARREDO FURNITURE

- 60 LV8 Qube
- 64 Beta racing-type cabinet

67 ATTREZZATURE E UTENSILERIA GARAGE EQUIPMENTS AND TOOLS

- 68 Wheel balancers and tyre changers
- 71 Wheel balancers and presses
- 73 Cranes, tanks and washing trays
- 75 Technical tanks
- 76 Chassis dynamometer
- 78 Moto race tools kit

85 IMPIANTISTICA PLANT DESIGN

- 86 Exhaust gas
- 88 Fluid Extraction







**L'AZIENDA
THE COMPANY**



LV8: 45 anni di storia

Ferrari Sergio Metalmeccanica, azienda leader nella carpenteria metallica media e leggera, è presente sul mercato da oltre 45 anni. Grazie all'esperienza e alle competenze tecniche si realizzano prodotti finiti, collaudati ed imballati, oltre a semilavorati per i più svariati settori: automotive, allestimento veicoli industriali, riscaldamento, arredamento, macchine utensili.

La "passione per le 2 ruote" e l'esperienza acquisita nel settore automotive portano nel 2002 all'ideazione del marchio LV8 ELEVATE. La Ferrari Sergio Metalmeccanica Srl comincia a produrre i primi cavalletti, accessori e attrezzature da officina all'avanguardia specifici per qualsiasi tipologia di moto.

LV8: 45 years of history

For more than 45 years on the market, Ferrari Sergio Metalmeccanica has been operating as a leading company in light and medium-size metal carpentry. Know-how, large experience and technical skills enable the company to manufacture, test and deliver both finished and semi-finished products for different fields of application such as: automotive, industrial vehicles, heating systems, furniture and machine-tools.

A "real passion for two-wheelers" along with a good experience acquired in the automotive field led to the creation of the LV8 ELEVATE brand in 2002. First stands, accessories and innovative garage equipment production began.



LV8 Oggi

LV8 fornisce alla propria clientela prodotti dalle elevate prestazioni affidabili nel tempo, un servizio accurato e puntuale ed una notevole esperienza nella progettazione e realizzazione di officine complete.

Competenza, cura artigianale, alta tecnologia, capacità progettuale e innovazione tecnica ed estetica si coniugano al meglio in tutti i prodotti della gamma LV8, capaci di offrire sempre soluzioni efficaci e all'avanguardia.

LV8 Today

LV8 offers its clients high performance products which can be relied upon to last, a prompt and reliable service and considerable expertise in designing and equipping complete workshops.

Competence, attention to detail, design skills, technological and aesthetics innovation are combined at their best in all the products of the LV8 range, which constantly offer effective and cutting-edge solutions.



Qualità e design italiano

LV8 è un'azienda attrezzata con le più moderne macchine a controllo numerico: tagli Laser automatizzati, piegatrici, isole di saldatura manuali e robotizzate e centri di lavoro CNC rappresentano il cuore tecnologico dell'Azienda.

Personale altamente specializzato e qualificato segue la messa a punto dei sistemi di trasformazione e cura nei minimi particolari, sino al processo di montaggio e collaudo di tutte le attrezzature.

Grazie a questa organizzazione LV8 è in grado di offrire ai propri Distributori e Clienti la miglior finitura dei prodotti e di conseguenza la massima qualità nel tempo oltre che un ottimo livello competitivo.

L'intera gamma di attrezzature e cavalletti moto LV8 è totalmente "made in Italy" e completamente realizzata con materiali certificati di prima qualità.

Italian quality and design

LV8 is equipped with the most modern numerical control machine tools: automated laser cutting systems, bending machines, manual and robotic welding stations, and CNC centres form the company's technological core.

Highly qualified and specialised staff deal with the fine tuning of the metal transformation processes and look after all the details, up to and including the mounting and testing of the equipment.

Thanks to the operation of the company, LV8 can offer its clients and distributors the best finish and therefore top quality products that are made to last and compare favourably with the competition.

The whole range of LV8 equipment and motorcycle lifts are made in their entirety in Italy and are completely fabricated with certified best-quality materials.



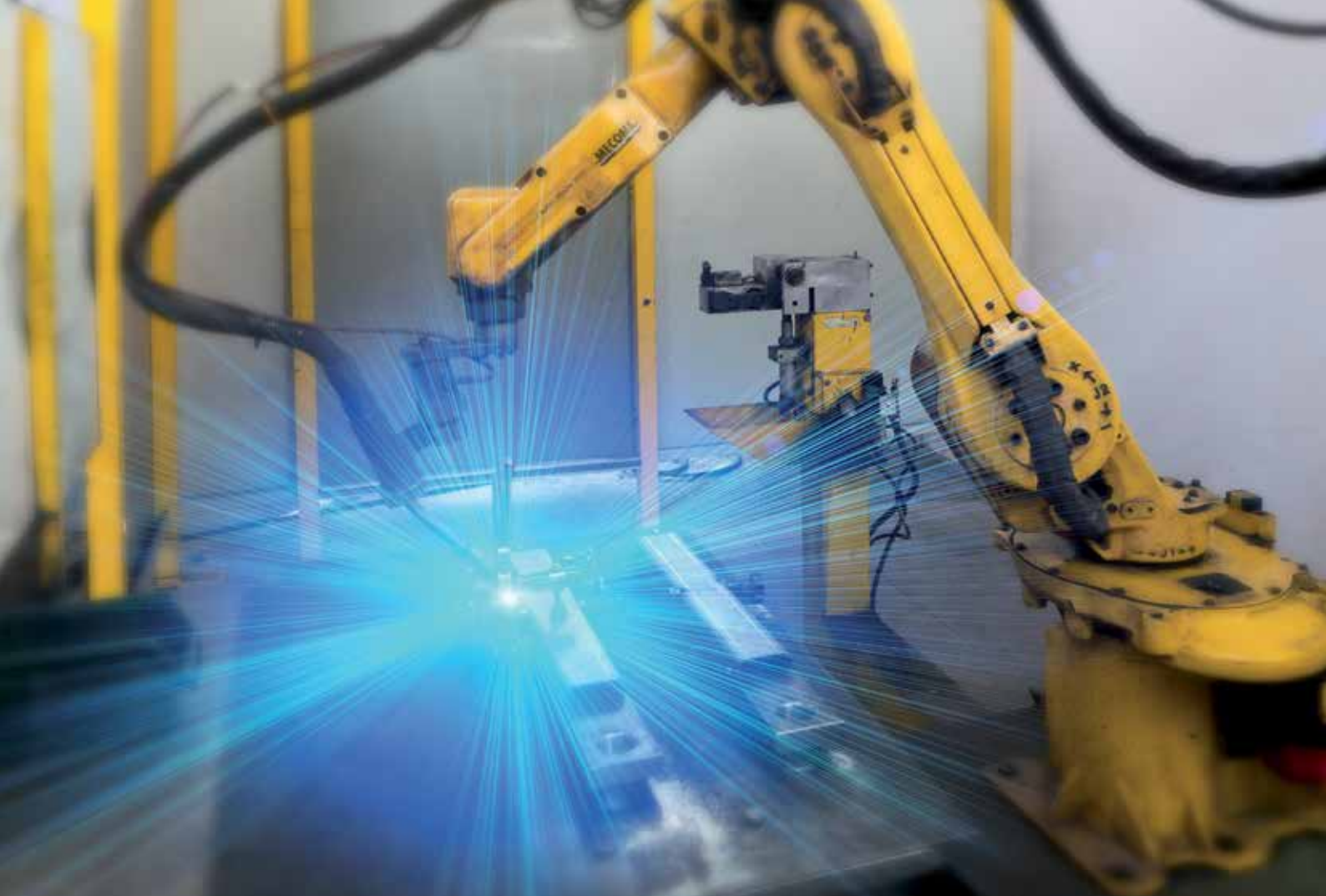





**CAVALLETTI MOTO
PADDOCK STANDS**



L&GO

PATENTED

Caratteristiche tecniche

- Sistema di connessione brevettato
- Inserimento manuale facile e veloce
- Nessun uso di viti e bulloni
- Verniciatura verde, bianca, rossa

Technical features

- Patented connection system
- Quick and easy manual connection
- No use of screws or bolts
- Green, white and red painting

100%
made in
ITALY

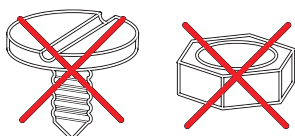

E620LV

Cavalletto posteriore universale con cursori a V
Universal rear stand with V fork cursors



E620LG

Cavalletto posteriore universale con cursori in gomma
Universal rear stand with rubber cursors



E620LV packaging
cm 51x45x11,5h



E620LG packaging
cm 51x45x11,5h



E600LC

Cavalletto anteriore universale - inclusi cursori anteriori a cono
 Universal front stand - front cone cursors included



E630L

Cavalletto monobraccio sinistro - senza perno - nero opaco std
 Left side single arm stand - without pin - mat black std



E600LC packaging
 cm 51x45x11,5h



E630L packaging
 cm 59x30,5x44h

DIAVOL

Caratteristiche tecniche

- Verniciatura nera opaca
- Senza saldature
- Porta cursore in poliammide
- 4 ruote in gomma termoplastica

Technical features

- Mat black painting
- No welding
- Cursor-holder in polyamide
- 4 rubber covered wheels

100%
made in
ITALY



E620/09

Cursori in gomma
Rubber cursors kit



E620D

Cavalletto posteriore universale. H: 36cm
Universal rear stand. H: 36cm



E620/08C

Cursori a V
V fork cursors kit



E620DL

Cavalletto posteriore LOW per Suzuki. **H: 30cm**
 Rear low stand for Suzuki. **H: 30cm**



E620/08C

Cursori a V
 V fork cursors kit



E620/08C

Imballo dei cursori
 Cursors kit packaging



E620DL+

Cavalletto posteriore LOW+ per Suzuki B-King e Hayabusa. **H: 27cm**
 Ideale per moto con nottolini in posizione ribassata e di peso elevato

Rear LOW+ stand for Suzuki B-King and Hayabusa. **H: 27cm**
 Suitable for heavy motorcycles with low-set bobbins

Colori disponibili

A = argento
N = nero
T = titanio

Available colours

A = silver
N = black
T = titanium



E201/08K

kit adattatori Triumph Street Triple e Tiger 800
Triumph Street Triple and Tiger 800 adapters kit



E201/06100 A
E201/06100 N
E201/06100 T

Nottolini in alluminio
M6x1 (Aprilia, Yamaha)
Aluminium bobbins
M6x1 (Aprilia, Yamaha)



E201/08125 A
E201/08125 N
E201/08125 T

Nottolini in alluminio
M8x1,25 (Suzuki, Honda, Ducati,
Triumph*)
Aluminium bobbins
M8x1,25 (Suzuki, Honda, Ducati,
Triumph*)

*per Triumph Speed Triple e Tiger 800 è necessario il kit E201/08K
E201/08K is necessary for Triumph Speed Triple and Tiger 800



E201/10100 A
E201/10100 N
E201/10100 T

Nottolini in alluminio
M10x1,50 (Ktm)
Aluminium bobbins
M10x1,50 (Ktm)



E201/10125 A
E201/10125 N
E201/10125 T

Nottolini in alluminio
M10x1,25 (Kawasaki)
Aluminium bobbins
M10x1,25 (Kawasaki)



E630DS

Cavalletto monobraccio per scooter BMW, senza perno
Single arm stand for BMW scooter, without pin



E630/03B28

Perno per scooter BMW escluso
BMW scooter pin not included

**E630/03K**

KTM 1290 Super Duke R

**E630/03D**

Ducati 748, 848, 916, 996, 998, Monster, Multistrada 1000/1100, Hypermotard

**E630/03DX**

Ducati DX/Right 848 08-10, 848 EVO

**E630/03D40**

Ducati 1098/1198, Diavel, Multistrada 1200, Streetfighter, Panigale

**E630/03D42**MV-Agusta e Ducati \varnothing 42 (1098/1198)**E630/03T**

Triumph Daytona, Speed Triple

**E630/03H**

Honda Crossrunner, VFR

**E630/03HC**

Honda CB1000R

**E630/03B30**

BMW F 650 CS, F800 S/ST

**E630/03B50.5**

BMW R 1200 GS/R/RT

**E630/03B52.9**

BMW K 1200, K 1300 R/S/RS/RT/GT, R 1200 S/ST, HP2

**E630D**Cavalletto monobraccio sinistro
Left side single arm stand**E630DR**Cavalletto monobraccio destro
Right side single arm stand



E620DB

Cavalletto posteriore per Triumph Bonneville - Truxton - Scrambler
Rear stand for Triumph Bonneville - Truxton - Scrambler



E600/03

Cursori a rulli
Roller cursors kit



E600/07

Cursori a cono
Cone cursors kit



E600/08

Cursori a cono asimmetrici
Asymmetric cone cursors kit



E600D

Cavalletto anteriore universale
Universal front stand



E601D

Cavalletto anteriore fisso
Front fixed stand



E600DH

Cavalletto anteriore alto per moto con pinza radiale
Front high stand for motorbikes with radial brakes



E620/07

Supporti in gomma per pinza radiale
Rubber cursors kit for radial brakes



Perno conico in acciaio
Steel conic pin



Piastra per MV-Agusta e Ducati
Plate for MV-Agusta and Ducati

E611S

Cavalletto anteriore a leva per canotto sterzo con perno universale e piastra per MV-Agusta e Ducati
Front under-yoke stand with lever with universal pin and plate for Mv-Agusta and Ducati



Kit 7 perni
7 pin kit

E610DP

Cavalletto anteriore per canotto sterzo
Front under-yoke stand



E640H

Cavalletto centrale per Honda VFR 1200 F e Crosstourer
Honda VFR 1200 F and Crosstourer central stand



E640H-PIN

Kit perni
Pin kit



E640

Cavalletto centrale universale a perno passante
Universal central stand with through axle



E640-PIN10

Perno Ø 10
Ø 10 pin



E640-PIN12

Perno Ø 12
Ø 12 pin



E640-PIN158

Perno Ø 15/8
Ø 15/8 pin



Supporti in gomma inclusi
Rubber cursors kit included



E601DT

Cavalletto anteriore fisso per T-MAX 2012 e successivi
Front fixed stand for T-MAX 2012 and later



E620DT

Cavalletto posteriore per T-MAX 2012 e successivi.
Inclusi cursori in gomma
Rear stand for T-MAX 2012 and later. Rubber cursors kit included



RACING

Caratteristiche tecniche

- Tubo in alluminio verniciato nero opaco
- Forchette in alluminio ricavate dal pieno, fissate al tubo mediante boccia ad espansione
- Supporti in alluminio ricavati dal pieno con rulli in nylon per pinze radiali, fissati al tubo mediante bocce ad espansione
- Ruote in nylon con cuscinetti a sfera

Technical features

- Aluminium pipe, mat black painted.
- Milled aluminium fork adaptors fixed through expansion bushes
- Milled aluminium adaptors with nylon rollers for radial brakes fixed through expansion bushes
- Nylon wheels with ball bearings

100%
made in
ITALY



E620RA

Cavalletto posteriore in alluminio
Aluminium rear stand

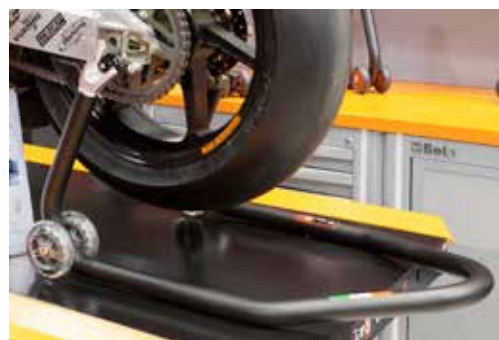

E600RA

Cavalletto anteriore in alluminio
Aluminium front stand



Cursori a forchetta in alluminio
Aluminium fork cursors



Cursori a rullo in alluminio
Aluminium rollers cursors

Dimensioni

- Altezza: 570mm
- Larghezza: 660mm
- Lunghezza: 2000mm
- Lunghezza rampa: 1950mm
- Peso: 29Kg
- Portata: 250Kg

Dimensions

- Height: 570mm
- Width: 660mm
- Length: 2000mm
- Ramp length: 1950mm
- Weight: 29Kg
- Capacity: 250Kg



**LEGGERO E PIEGHEVOLE.
LIGHT AND FOLDABLE.**

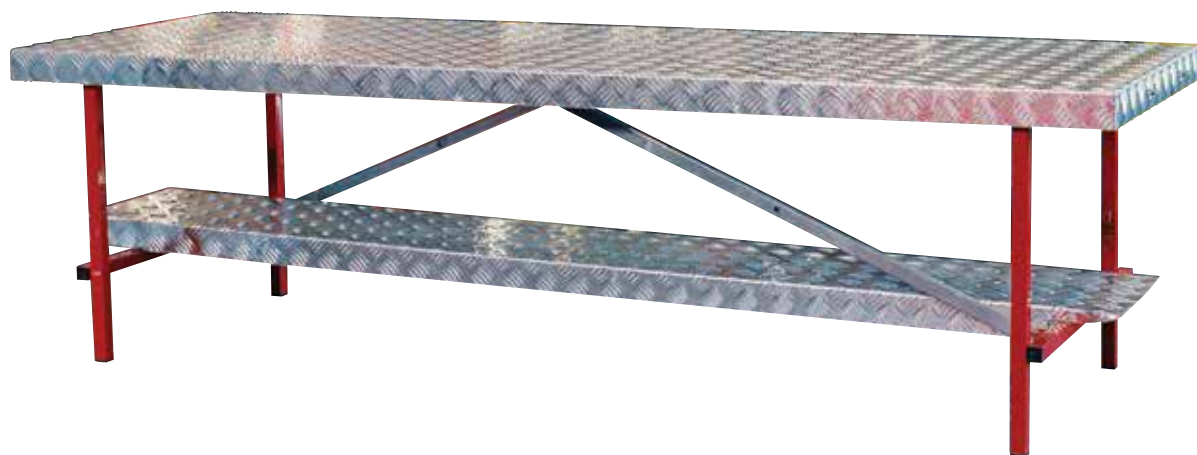

E400R

Banco di lavoro in alluminio antiscivolo con piedi richiudibili e rampa di salita removibile
Anti-skid aluminium workbench with foldable tubular legs and removable ramp



E900T

Coppia cavalletti centrali per telaio con asta inclusa (H: 67-102cm)
Central stands for frame with steel tube rod (H: 67-102cm)



E900P

Coppia cavalletti centrali per pedana poggia piedi (H: 38-56cm)
Central stands for footpeg rests (H: 38-56cm)

OFF ROAD

100%
made in
ITALY



Caratteristiche tecniche

Assolutamente innovativo per i suoi 31 cm di altezza da chiuso. Pertanto non è più necessario alzare manualmente la moto per appoggiarla sul sollevatore. Nessuno sforzo fisico, ergonomia e semplicità d'uso.

- Altezza minima: 310mm
- Altezza massima: 900mm
- Larghezza: 340x460mm
- Portata: 250Kg

Technical features

Fully innovative due to its 31 cm height when completely lowered. No manual lifting of motorcycle needed and no physical effort to position it on the lift. Ergonomic and user-friendly.

- Maximum height: 310mm
- Minimum height: 900mm
- Width: 340x460mm
- Capacity: 250Kg

E800Y

Sollevatore idraulico a pedale off- road con piano in legno
Foot pedal operated hydraulic off-road motorcycle lift with wood table



E800Y-PR.K

Piano rotante optional per E800Y
Optional E800Y turnable table



E800Y-M

Moving optional per E800Y
Optional E800Y moving





Dimensioni

- Altezza minima: 290mm
- Altezza massima: 400mm.
- Appoggio: 300x150mm.
- Peso: 7,5Kg

Dimensions

- Minimum height: 290mm
- Maximum height: 400mm.
- Support: 300x150mm.
- Weight: 7,5Kg

E800L

Cavalletto Cross
Cross stand



Dimensioni

- Altezza minima: 250mm
- Altezza massima: 350mm.
- Appoggio: 300x230mm.
- Peso: 7,5Kg

Dimensions

- Minimum height: 250mm
- Maximum height: 350mm.
- Support: 300x230mm.
- Weight: 7,5Kg

E800M

Cavalletto Motard
Motard stand



E800CF

Cavalletto cross racing in alluminio
Aluminium racing cross stand

Dimensioni

- Altezza: 410mm
- Appoggio: 300x220mm.
- Peso: 2,5Kg

Dimensions

- Height: 410mm
- Support: 300x220mm.
- Weight: 2,5Kg

GARAGE & TRACK

100%
made In
ITALY

Caratteristiche tecniche

“Sotto cavalletto” utilizzabile con tutte le moto e scooter provviste di cavalletto centrale. Equipaggiato con 4 ruote girevoli in poliuretano, due delle quali con freno, consente di spostare la moto in tutte le direzioni agevolandone il parcheggio in garage, anche in spazi ristretti. Disponibile l'estensione anche per il cavalletto laterale.

Technical features

“Under stand” for any kind of motorcycle or scooter with central stand. Equipped with 4 polyurethane caster wheels (2 with brakes), it is used to move the motorbike in all directions making parking operations in the garage and in tight spaces easier. Extension for side stand available.



E300MM+

Motomoving con copertura in gomma antiscivolo
Motomoving with anti-skid rubber covering



E300MM-EXT

Estensione per cavalletto laterale
Extension for side stand



EWCAF

Morsa automatica per furgone
Automatic wheel vise for trucks and vans



EWCAF.KC

Set due flange per fissare la morsa automatica ai carrelli a binario
Two flange set to fix automatic wheel vise on trailer with lanes.



EWCAF.KP

Set piedi di allargamento per morsa per furgoni con appoggi in plastica
Enlargement foot set with plastic feet for automatic wheel vise.





ERAMP

Rampa in alluminio (30x182cm)
Aluminium ramp (30x182cm)



BETA.081880430

8188CG/25



BETA.081880530

8188FG2



BETA.081880930

8188/E15 espositore da banco con 15 cinghie assortite
8188/E15 counter display with 15 ratchet tie downs

Codice Code	Descrizione Description	N.
BETA.081880430	8188CG/25 legatura cricchetto 2 ganci e asole (3m) 8188CG/25 ratchet tie down with 2 s-hooks and eyes (3m)	4
BETA.081880450	8188CG/25 legatura cricchetto 2 ganci e asole (5m) 8188CG/25 ratchet tie down with 2 s-hooks and eyes (5m)	3
BETA.081880530	8188FG2 legatura fibbia 2 ganci e asole (3m) 8188FG2 cam buckle strap with 2 s-hooks and eyes (3m)	2
BETA.081880630	8188FG3 legatura fibbia 3 ganci e asole (3,5m) 8188FG3 cam buckle strap with 3 s-hooks and eyes (3,5m)	2
BETA.081880290	8188F/35 legatura ad anello con fibbia (4m) 8188F/35 cam buckle strap (4m)	4





**CARICABATTERIA E AVVIATORI
BATTERY CHARGER AND BOOSTER**



SHIELD LT

100%
made in
ITALY



ECBSLT01

SHIELD LT caricabatteria elettronico
SHIELD LT electronic battery charger

Caricabatteria elettronico di ultima generazione, cicli di analisi, carica multifase e mantenimento.

Il microprocessore adottato gestisce in maniera totalmente automatica la carica di tutti i tipi di batterie al piombo e litio (LifePO4). Ideale per tutte le moto, auto d'epoca, trattorini rasaerba

Doppia carica: adatti per tutti i tipi di batterie al Pb: Wet, Gel, Agm, Mf, Vrla

SHIELD LT è inoltre compatibile con il CAN-bus delle moto, è protetto da inversione di polarità e corto circuito.

Nuova forma esclusiva ed ergonomica, nuovi accessori di ricarica con connettori IP65.

Ultimate electronic charger, digital, digital and multiphases.

The microprocessor manages automatically selection of multiphase charging cycles of all type of lead batteries and also lithium batteries (Life-PO4). Ideal for all motorcycles, vintage cars, lawn tractors etc

Dual charge: suitable for all types of lead batteries Wet, Gel, AGM, MF,Vrla

SHIED LT has CAN-Bus bypass, It is also protected against reverse polarity, short circuit.

New exclusive and ergonomic design, new charging accessories IP65 connectors.

Caratteristiche Tecniche:

- Protezione inversione polarità e corto circuito
- Ciclo di ricarica multifase automatico
- Cicli di test e analisi automatici
- Ciclo di desolfatazione ad impulsi
- Due specifici tipi di carica per batterie al Pb e Litio(LiFePO4)
- Protetto dall'acqua IP65
- Funzione recupero batteria, tentativo di ricarica batterie molto scariche fino a 2Volt

Accessori in dotazione:

- Cavi con pinze 30A e
- Cavi con occhielli Ø 6mm + fusibile

Technical Features:

- Reverse polarity, Short Circuit protection
- Multiphase automatic charging cycle
- Automatic testing phases
- Desulfating pulse phase
- Dual specific mode of charge for Pb or lithium(LiFePO4) batteries
- Waterproof IP65
- Recovery mode charging, try to recharge very discharge battery up to 2Volt

Standard Equipments:

- Cable with clamps 30°
- Cable with rings Ø 6mm + fuse

Componente Component	SHIELD LT
Tensione Voltage	220/240
Corrente Power Supply	1A
Grado di Protezione Protection Degree	IP65
Frequenza Frequency	50/60 HZ
Tensione Batteria Battery Voltage	12V
Capacità di Carica Charge Capacity	2A/h - 40A/h
Capacità di Mantenimento Maintenance Capacity	4A/h - 100A/h
Dimensioni Size (Mm)	180(L)x80(W)x40(H)
Peso Weight	0,5 kg



Cavo con pinze 30A
Cable with clamps 30A



Cavetto con occhielli Ø 6mm
e fusibile
Cable with ring Ø 6mm
and fuse

SHIELD 8

100%
made in
ITALY



ECBS0801

SHIELD 8 caricabatteria elettronico
SHIELD 8 electronic battery charger

Caricabatteria elettronico digitale, multifase di carica e mantenimento.

Il microprocessore adottato gestisce in maniera totalmente automatica la carica di tutti i tipi di batterie al piombo, Wet, Gel, Agm, Mf, Vrla SHIELD 8 è in grado di selezionare in maniera totalmente automatica la tensione di carica (6V o 12V) e automaticamente gestisce anche il ciclo di carica multifase più idoneo. Dotato di funzione specifica per la ricarica invernale.

Nuova forma esclusiva ed ergonomica. Nuovi accessori di ricarica con connettori IP65

The ultimate Electronic charger, digital and multiphases of charge and maintenance.

The microprocessor manages automatically the selection of 6V or 12V tension, and automatic is also the selection of multiphase charging cycles. With a Winter mode charging.

Suitable for all types of lead batteries Wet, Gel, AGM, MF, Vrla,

New exclusive and ergonomic design. New charging accessories IP65 connectors

Caratteristiche Tecniche:

- Protezione di inversione polarità e c.c.
- Selezione automatica della tensione 6/12V
- Ciclo di ricarica multifase automatico
- Display grafico retroilluminato
- Funzione tester batteria e alternatore
- Gancio di fissaggio reclinabile
- Protetto dall'acqua IP65
- Funzione di ricarica invernale

Technical Features:

- Reverse polarity, Short Circuit protection
- Automatic voltage selection 6 or 12 Volt
- Multiphase automatic charging cycle
- Graphic Digital display with backlight
- Battery & Alternator Voltage Tester
- Reclining hook fastening
- Waterproof IP65
- Winter mode charging

Accessori in dotazione:

- Cavi con pinze 30A e

Standard Equipments:

- Cable with clamps 30°

Componente Component	SHIELD 8
Tensione Voltage	220/240
Corrente Power Supply	1/4A
Grado di Protezione Protection Degree	IP65
Frequenza Frequency	50/60 HZ
Tensione Batteria Battery Voltage	6/12V
Capacità di Carica Charge Capacity	4A/h - 80A/h
Capacità di Mantenimento Maintenance Capacity	4A/h - 120A/h
Dimensioni Size (Mm)	190(L)x80(W)x50(H)
Peso Weight	0,75 kg



Cavo con pinze 30A
Cable with clamps 30A

MOTORBIKE BATTERY MAINTENANCE STATION

100%
made in
ITALY



Studiata per offrire una postazione ergonomica ed efficiente dedicata alla preparazione e manutenzione delle batterie al piombo e al litio.

Può essere attrezzata fino ad un massimo di dodici carica batterie, a propria scelta tra i due modelli disponibili (CARICABATTERIA + MANTENITORE 6v-12v 4A oppure 12v 1A LITHIUM - CANBUS (BMW).

Il piano di lavoro a vasca e i ripiani per alloggiamento batterie sono realizzati in acciaio inox per consentire una facile pulizia e migliore conservazione nel tempo in caso di sversamento degli acidi utilizzati.

I componenti del banco batterie sono al 100% integrabili nelle configurazioni LV8 Qube o costituire postazioni di lavoro autonome e separate dal resto dell'officina, scegliendo la configurazione preferita dei piedi e del modulo sotto piana (armadietto o cassetiera) per lo stoccaggio di materiale di consumo o attrezzatura elettronica specifica.

Designed to offer an ergonomic and efficient location dedicated to the preparation and maintenance of lead and lithium batteries.

It can be equipped with up to a maximum of twelve battery chargers, at your choice between the two models available (CHARGER + MAINTENANCE 6v-12v 4A or 12v 1A LITHIUM - CANBUS (BMW).

The worktop with hand washer and battery storage shelves are made of stainless steel for easy cleaning and better storage over time in case of spillage of the acids used.

Battery components can be easily 100% integrated into LV8 Qube configurations or can be autonomous workstations, separated from the rest of the workshop, choosing the preferred legs configuration and the modular combination under the worktop (cabinet or drawer units) for storing consumables or specific electronic equipment.

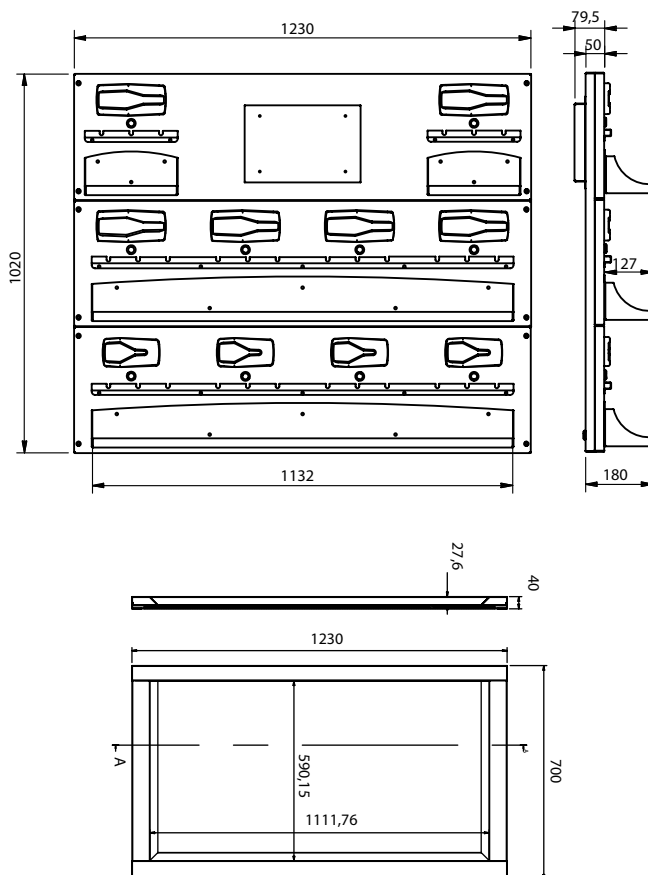

Stazione di manutenzione batterie moto
Motorbike battery maintenance station

SHOCK



EJS001

SHOCK Aviatore portatile al litio multifunzione
SHOCK Multipurpose booster lithium technology

Il booster Shock è un aviatore portatile di emergenza con batteria al litio multifunzione.

Adatto all'avviamento di batterie a 12V per tutti i tipi di moto e a 12V per motori a benzina fino a 3000 CC o Diesel fino a 2000 CC (motoveicoli, autoveicoli, imbarcazioni, rasaerba). Il booster Shock permette di alimentare e/o caricare i dispositivi elettronici quali smartphone e tablet. Le ridotte dimensioni fanno dell'aviatore Shock un booster maneggevole e compatto. Dotato di luce led per illuminazione, con funzione flash e SOS.

The Shock multipurpose booster is a portable emergency starter with a lithium battery.

Suitable for boosting 12V batteries for all types of motorcycle and 12V batteries for petrol engines up to 3000 cc or diesel engines up to 2000 cc (motor vehicles, boats, lawnmowers). The Shock booster allows users to power and/or charge electronic devices such as smartphones and tablets. The small size makes the Shock booster compact and easy to handle. Equipped with Led for flash and SOS lighting.

Caratteristiche Tecniche:

- Aviatore portatile multifunzione con batteria al litio
- Caricabatterie portatile per tablet e smartphone
- Dotato di luce led continua/intermittente con funzioni flash e SOS
- Compatibile per qualsiasi tipo di avviamento a 12V

Accessori in dotazione:

- Confezione con apertura a libro
- Kit con caricabatteria da muro o da auto
- Cavi con pinze isolate
- Cavo adattatore tra porta USB del booster e le diverse prese di alimentazione e/o ricarica dei principali dispositivi elettronici in commercio

Technical Features:

- Multifunctional Booster Lithium
- Portable battery charger for tablet and smartphone
- Ultra light torch led with flash and SOS lighting pupose
- Suitable for any boosting 12V batteries

Standard Equipments:

- Bookflap Box
- KIT Full Optional with power adapter and car charger
- Storage battery wir clip
- Usb cable with charge adapter + four-in-one mobile phone adapter

Componente Component	SHOCK
Capacita' di Batteria Battery Capacity	8000 mAh
Usb port Usb port	5V 2,1A
Input Input	DC15V/1A
Inizio di Corrente Starting Current	200A ~ 380A
Picco di Corrente Peak Current	400A
Dimensioni Size	132x75x15 mm
Peso Weight	0,23 kg



Confezione con apertura a libro
Bookflap box



Caricabatteria da casa e da auto
Mains power supplier and car power supplier



Torcia luminosa a Led
Bright Led light



Adattatori USB per tablet e
smartphone
USB cable with adapter for tablet
and smartphone



TUMORON

Ricerca e Sviluppo

Lv8

Lv8

Lv8

Lv8

RELEVATE



**SOLLEVATORI MOTO
MOTORCYCLE LIFTS**



NANO

ALTEZZA MINIMA 75MM (3")
MINIMUM HEIGHT 75MM (3")

Caratteristiche tecniche

- Comandi uomo presente, 24V
- Sicurezze elettriche
- Sicurezze idrauliche
- Portata 350/500/600Kg
- Adatto per essere installato a pavimento o a scomparsa
- Completo di tubazioni idrauliche premontate per installazione centralina

Technical Features

- "Dead man" controls 24V
- Electrical safety devices
- Hydraulic safety devices
- Capacity 350/500/600Kg
- Suitable for recessed installation or on the floor
- Equipped with pre-mounted hydraulic pipes enabling the installation of the control unit

100%
made in
ITALY



Dotazioni di serie

- 2 vaschette porta utensili laterali
- Rampa di salita
- Fermaruota
- Carter per protezione tubazioni

Standard Equipments

- 2 side tools holders
- Run-up ramp
- Front safety bar
- Pipe protection cover



ZERTIFIKAT • CERTIFICATE • CERTIFICADO • CERTIFICAT • CERTIFICADO • CERTIFICAT

TUV SUD

CERTIFICATO
Zertifikat

Certificato Nr. / Zertifikat Nr.: TUV 01 13 MAC 0028

Richiedente: / Applicant: Ferrari Sergio Metallmeccanica Srl
Via Peppone Don Camillo, 11
42041 - Braconno (RE)

Data della domanda: / Date of request: 03/03/2013

Numero d'ordine: / Order Auftragsnummer: 231106

Fabbricante: / Manufacturer Hersteller: Ferrari Sergio Metallmeccanica Srl
Via Peppone Don Camillo, 11
42041 - Braconno (RE)

Prodotto / modello: / Product / Model: Sollevatori per motocicli
vehicle lift
Motorcycle hoists for Passenger
NANO 550 / NANO 600

Data e numero test report: / Date and report Nr.: 15042013 - IS 231106 002 TR

Nome di riferimento: / Full standard Prüfverfahren: Direttiva macchine 2006/42/CE
Machinery directive 2006/42/CE
EU-Richtlinie 2006/42/EG (Maschinenrichtlinie)

Risultato: / Result: Il dispositivo soddisfa i requisiti fondamentali di sicurezza nel campo di applicazione riportato nel report.
Das Gerät erfüllt für alle im Publikums angegebenen Anwendungsgebiete die grundlegenden Sicherheitsanforderungen.

Data di emissione: / Date of issue: 15/04/2013

Data di scadenza: / Expiration date: 16/04/2016

Sig. Sergio Don Giovanni (MI)
Il sig. sottoscrive le informazioni.
Please see attached certificate.

TUV Italia • Piazza TUV 6/20 • Via Garibaldi 125, Tel. 02 • 20098 Segrate (MI) • www.tuv.it • Italia • www.tuv.com

Modello Model	Portata Capacity	Gate	Con centralina elettrica With electro-hydraulic unit
Nano 350 Garage	350Kg	X	X
Nano 350 Track	350Kg		X
Nano 500 Garage	500Kg	X	X
Nano 500 Track	500Kg		X
Nano 600 Garage NEW	600Kg	X	X



EIE-LTPNK01 OPTIONAL

Kit radiocomando 2400MHZ
2400MHZ remote control kit



Centralina elettroidraulica
Electro-Hydraulic unit



Due cilindri di sollevamento
Two lifting cylinders



Fermaruota
Front safety bar



Gate 52x29cm
Gate 52x29cm



Vaschette portautensili laterali
Side tools holders



Rampa di salita
Run-up ramp



Sistema di scorrimento a patini in plastica autolubrificante
Skid sliding system with self-lubricating plastic material



EN350GE

NANO 350 GARAGE

Con centralina elettroidraulica
With electro-hydraulic unit

EN350GEF

NANO 350 GARAGE FLOOR

Versione a incasso
Floor version

CAPACITY
350KG

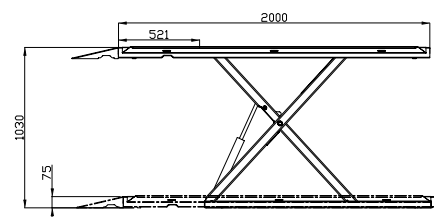
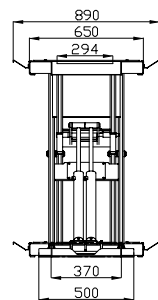

EN350TE

NANO 350 TRACK

Con centralina elettroidraulica
With electro-hydraulic unit

EN350TEF

NANO 350 TRACK FLOOR

Versione a incasso
Floor version

CAPACITY
350KG

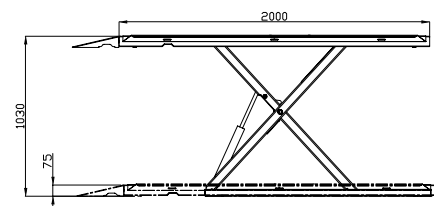
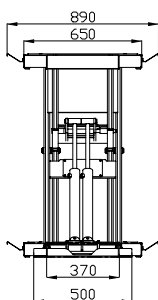



EN500GE

NANO 500 GARAGE

Con centralina elettroidraulica
With electro-hydraulic unit

EN500GEF

NANO 500 GARAGE FLOOR

Versione a incasso
Floor version

CAPACITY
500KG

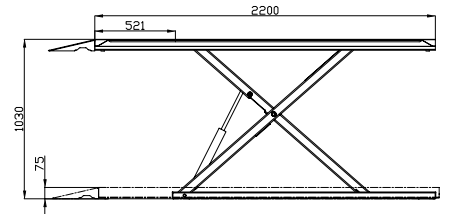
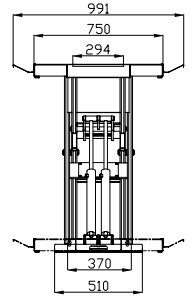

EN500TE

NANO 500 TRACK

Con centralina elettroidraulica.
With electro-hydraulic unit.

EN500TEF

NANO 500 TRACK FLOOR

Versione a incasso
Floor version

CAPACITY
500KG

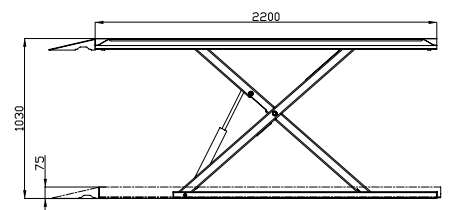
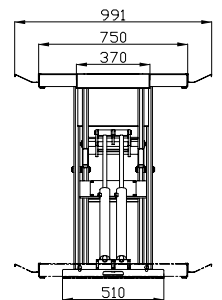

NANO 600

ALTEZZA MINIMA 75MM (3")
MINIMUM HEIGHT 75MM (3")

Caratteristiche tecniche

- Comandi uomo presente, 24V
- Sicurezze elettriche
- Sicurezze idrauliche
- Portata 600kg
- Alimentazione Elettrica 220V 1ph
- Adatto per essere installato a pavimento o a scomparsa
- Completo di tubazioni idrauliche lung. 2 mt premontate per installazione centralina
- Base e leve allargate
- Uscita tubi anteriore

Technical Features

- "Dead man" controls 24V
- Electrical safety devices
- Hydraulic safety devices
- Capacity 600Kg
- Power Supply 220V 1 ph
- Suitable for recessed installation or on the floor
- Equipped with pre-mounted hydraulic pipes length 2 mt. enabling the installation of the control unit
- Base and levers extended
- Front output pipes

100%
made in
ITALY



Dotazioni di serie

- 2 vaschette porta utensili laterali
- Rampa di salita a scomparsa
- Ferma ruota
- Carter per protezione tubazioni

Standard Equipments

- 2 side tools holders
- Retractable run-up ramp
- Front safety bar
- Pipe protection cover



Modello Model	Portata Capacity	Gate	Con centralina elettrica With electro-hydraulic unit
Nano 600 Garage	600Kg	X	X
Nano 600 Garage Floor	600Kg	X	X

CERTIFICATO CERTIFICATE

Direttiva Macchine 2006/42/CE All. IX. Esame CE del tipo per ponti elevatori per veicoli (Rif. Allegato IV - 16)

Machinery Directive 2006/42/EC Annex IX. EC type-examination certificate for vehicles servicing lifts according to Machinery Directive 2006/42/EC (ref. Annex IV - 16)

Certificato No.: TÜV IT 0948 17 MAC 0085 B
Certificate No.:

Data della domanda: 12 Maggio 2016
Date of submission:

Nome ed indirizzo del fabbricante: Ferrari Sergio Metalmeccanica S.r.l.
Name and address of manufacturer:
Sede Legale:
Via A. Novati, 46
42046 Sorbolo (PR) - Italia
Sede Operativa:
Via Piagnone e Don Camillo, 11
42041 Brescello (RE) - Italia

Prodotto: Sollevatore moto
Product: Motorcycle lift

Modello tipo: NANO 600
Model type:

Norme di riferimento: EN 1493:2010
Reference Standards:

Rapporto di prova: TR 0948 MAC 0080 B, 25/01/2017
Test report:

Si certifica che il ponte elevatori per veicoli nel campo di applicazione riportato nell'allegato al presente certificato soddisfa i requisiti della direttiva:

We hereby certify that the vehicle servicing lift for the respective scope of application stated in the annex to this EC type-examination certificate meets the requirements of the Directive:

2006/42/CE

Data 1a emissione: 27/01/2017
First issue date:

Data emissione: 27/01/2017
Issue date:

Data di scadenza: 26/01/2022
Expiry date:



TÜV Italia S.r.l.
Organismo notificato N° 0948
Notified Body, Identification N° 0948

Ferrari Sergio
Industria Specifica Division Manager

PMA 01_M001 (ex PMA 08_M001_v002 del 07/06/2016)



EIE-LTPNK01 OPTIONAL

Kit radiocomando 2400MHZ
2400MHZ remote control kit



Centralina elettroidraulica
Electro-Hydraulic unit



Due cilindri di sollevamento
Two lifting cylinders



Ferma ruota
Front safety bar



Gate 52x29cm
Gate 52x29cm



Vaschette portautensili laterali
Side tools holders



Rampa di salita a scomparsa
Retractable run-up ramp

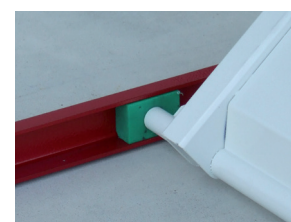

Sistema di scorrimento a pattini in plastica autolubrificante
Skid sliding system with self-lubricating plastic material

CAPACITY
600KG

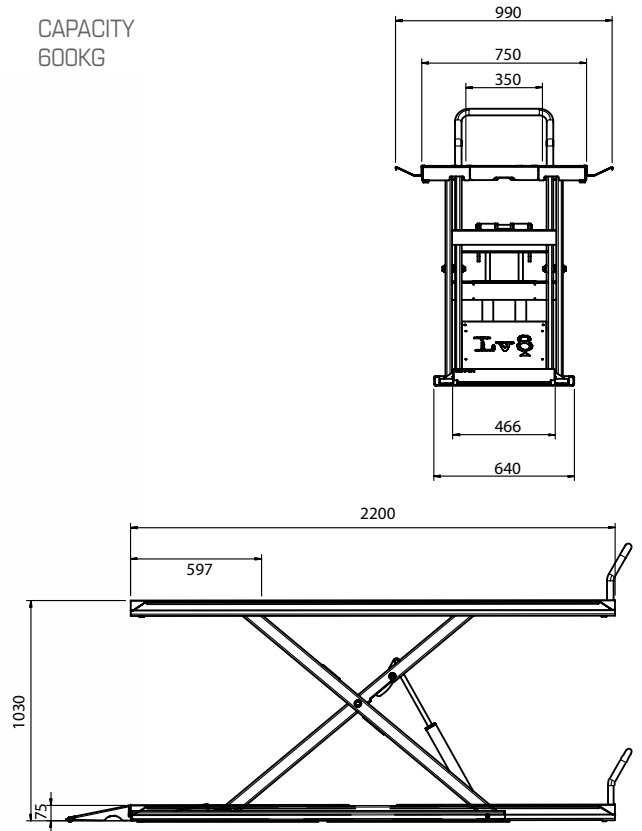

EN600GE

NANO 600 GARAGE

Con centralina elettroidraulica
With electro-hydraulic unit

EN600GEF

NANO 600 GARAGE FLOOR

Versione a incasso
Floor version



COMPARISON TABLE	NANO 500	NANO 600
Capacità Capacity	500 Kg	600 Kg
Rampa Ramp	Fissa Fixed	Mobile Retractable
Base e leve Base and forks	Strette Tight	Allargate Enlarged
Uscita tubi Output pipes	Posteriore Rear	Anteriore Front

GOLDRAKE

Caratteristiche tecniche

- Sicurezze elettriche
- Sicurezze meccaniche
- Sicurezze idrauliche
- Portata: 200/350/400/500/600/800kg
- Centralina elettroidraulica integrata

Technical Features

- Electrical Safety device
- Mechanical safety device
- Hydraulic safety devices
- Capacity: 200/350/400/500/600/800 kg
- Integrated electro-hydraulic unit

Dotazioni di serie

- 2 vaschette porta utensili laterali (optional per Goldrake junior 200kg)
- Rampa di salita
- Fermaruota

Standard Equipments

- 2 side tools holders (optional for Goldrake junior 200kg)
- Run-up ramp
- Front safety bar

100%
made in
ITALY



Modello Model	Portata Capacity	Gate	Con centralina elettrica With electro-hydraulic unit	Con pompa oleopneumatica With hydraulic air pump	Con pompa a pedale With foot pedal pump
Goldrake Junior	200Kg			X	X
Goldrake 350 Moto	350Kg		X	X	X
Goldrake 500 ICKS NEW	500Kg		X		
Goldrake 600 Moto	600Kg		X	X	X
Goldrake 600C Moto	600Kg	X	X	X	X
Goldrake 600HC Moto	600Kg	X	X	X	
Goldrake 600HCF Moto	600Kg	X	X	X	
Goldrake 800HC Moto	800Kg	X	X		
Goldrake 800HCF Moto	800Kg	X	X		
Goldrake 800HCS Moto	800Kg	X	X		
Goldrake 400 Quad	400Kg	X	X		
Goldrake 600 Quad	600Kg	X	X	X	X



Centralina elettroidraulica
Electro-hydraulic unit



Pompa oleopneumatica
Hydraulic air pump



Pompa a pedale
Foot pedal pump



Rampa di salita
Run-up ramp



Fermaruota
Front safety bar



Gate 60x35cm
Gate 60x35cm



Vaschette portautensili laterali
Side tools holders



EIE-LTPNK01 **OPTIONAL**

Kit radiocomando 2400MHZ
2400MHZ remote control kit



CAPACITY
200KG

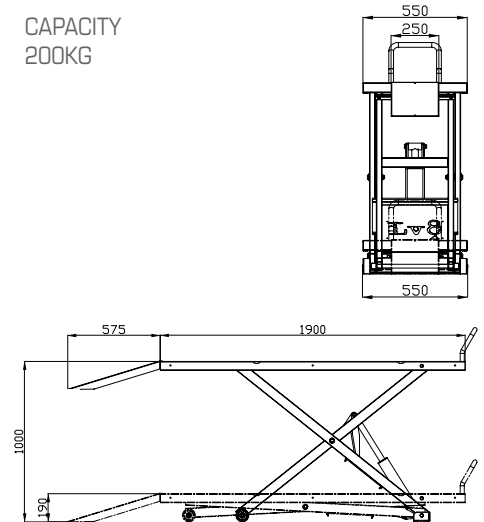

EG200JO

GOLDRAKE JUNIOR

Con pompa oleopneumatica
With hydraulic air pump

EG200JP

GOLDRAKE JUNIOR

Con pompa a pedale
With foot pedal pump

EG200JP-VP

Vaschette portautensili optional

Optional tools holders



CAPACITY
350KG

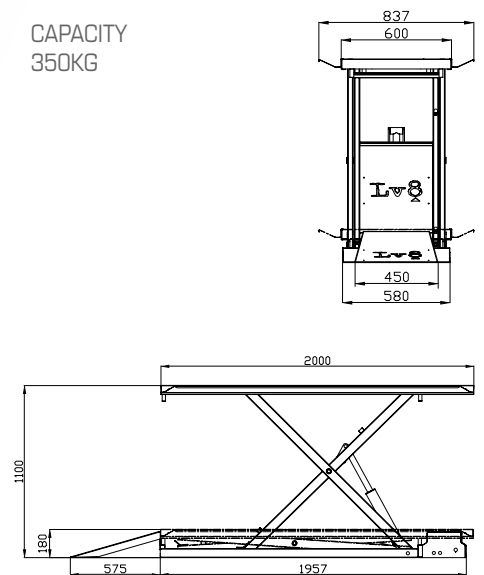

EG350E

GOLDRAKE 350 MOTO

Con centralina elettroidraulica
With electro-hydraulic unit

EG3500

GOLDRAKE 350 MOTO

Con pompa oleopneumatica
With hydraulic air pump

EG350P

GOLDRAKE 350 MOTO

Con pompa a pedale
With foot pedal pump



CAPACITY
600KG

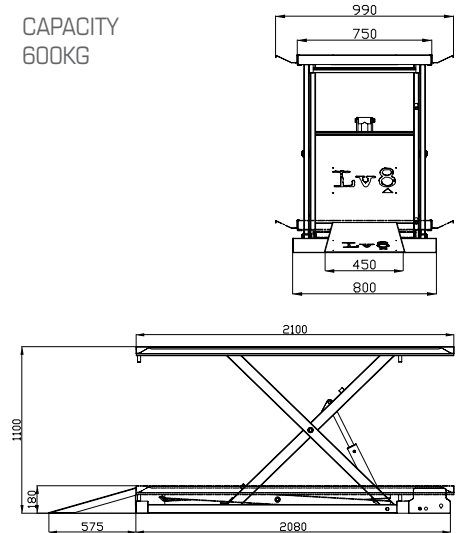

EG600E

GOLDRAKE 600 MOTO

Con centralina elettroidraulica
With electro-hydraulic unit

EG6000

GOLDRAKE 600 MOTO

Con pompa oleopneumatica
With hydraulic air pump

EG600P

GOLDRAKE 600 MOTO

Con pompa a pedale
With foot pedal pump



CAPACITY
600KG

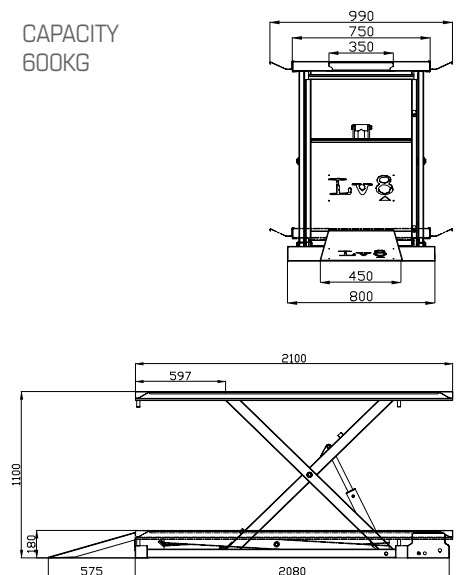

EG600CE

GOLDRAKE 600C MOTO

Con centralina elettroidraulica
With electro-hydraulic unit

EG600CO

GOLDRAKE 600C MOTO

Con pompa oleopneumatica
With hydraulic air pump

EG600CP

GOLDRAKE 600C MOTO

Con pompa a pedale
With foot pedal pump



EG600HCE

GOLDRAKE 600HC MOTO

Con centralina elettroidraulica
With electro-hydraulic unit

EG600HCO

GOLDRAKE 600HC MOTO

Con pompa oleopneumatica
With hydraulic air pump

CAPACITY
600KG

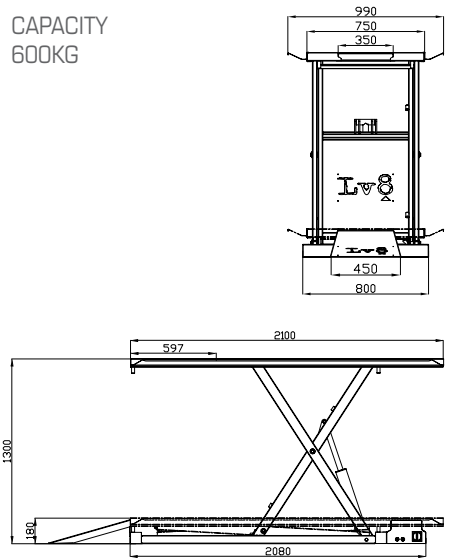

Personalizzazioni colore a richiesta
Customized colour on request



EG800HCE

GOLDRAKE 800HC MOTO

Con centralina elettroidraulica
With electro-hydraulic unit

EG800HCO

GOLDRAKE 800HC MOTO

Con pompa oleopneumatica
With hydraulic air pump

CAPACITY
800KG

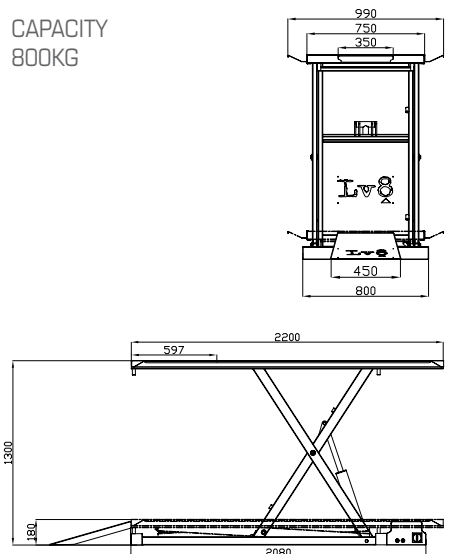

CAPACITY
800KG

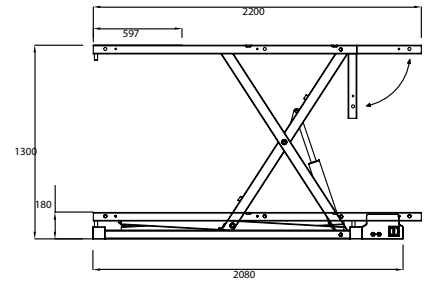
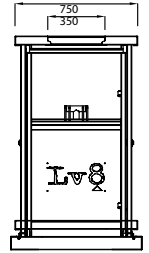

EG800HCSE

GOLDRAKE 800HC MOTO SPLIT VERSION

Con centralina elettroidraulica
With electro-hydraulic unit





EG600HCFE

GOLDRAKE 600HCF MOTO FLOOR

Con centralina elettroidraulica
With electro-hydraulic unit

CAPACITY
600KG

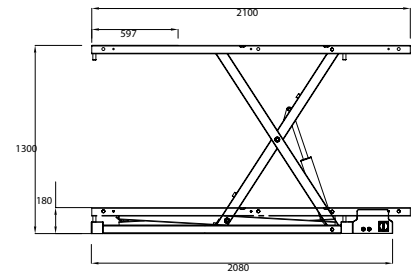
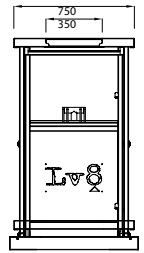

EGHCF600

FLOOR FRAME

214x79x17cm



EG800HCFE

GOLDRAKE 800HF MOTO FLOOR

Con centralina elettroidraulica
With electro-hydraulic unit

CAPACITY
800KG

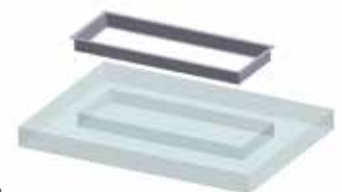
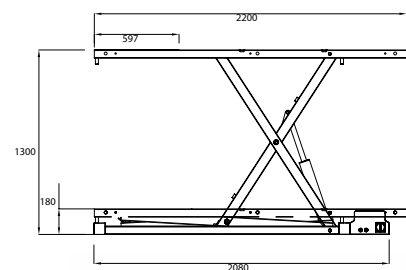
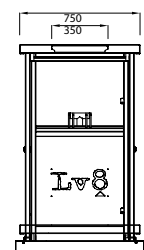

EGHCF800

FLOOR FRAME

224x79x17cm



CAPACITY
400KG

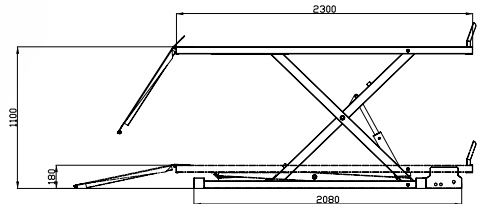
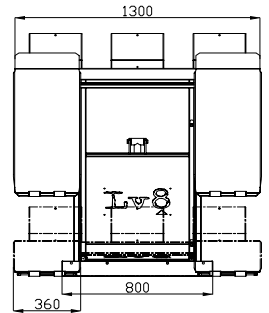

EG400QE

GOLDRAKE 400 QUAD
Con centralina elettroidraulica
With electro-hydraulic unit

EG400QO

GOLDRAKE 400 QUAD
Con pompa oleopneumatica
With hydraulic air pump

EG400QP

GOLDRAKE 400 QUAD
Con pompa a pedale
With foot pedal pump

EG400Q-R3

Rampa centrale optional per veicoli a tre ruote
Optional central ramp for 3-wheeler-vehicles



CAPACITY
600KG

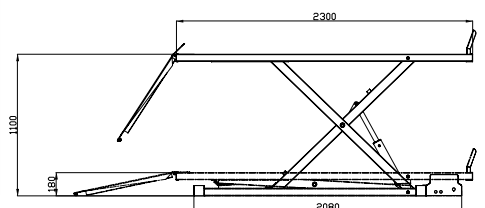
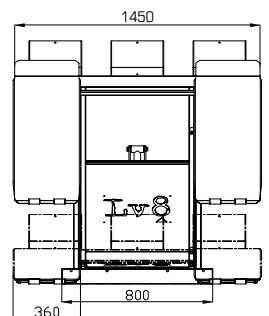

EG600QE

GOLDRAKE 600 QUAD
Con centralina elettroidraulica
With electro-hydraulic unit

EG600QO

GOLDRAKE 600 QUAD
Con pompa oleopneumatica
With hydraulic air pump

EG600QP

GOLDRAKE 600 QUAD
Con pompa a pedale
With foot pedal pump

GOLDRAKE 500 ICKS

Caratteristiche tecniche

- Comandi uomo presente, 24V
- Sicurezze elettriche
- Sicurezze idrauliche
- Portata: 500kg
- Alimentazione Elettrica 220V 1ph
- Centralina elettroidraulica integrata
- Piano Rotante 360° con interblocchi

Technical Features

- "Dead man" controls 24V
- Electrical Safety device
- Hydraulic safety devices
- Capacity: 500 kg
- Power Supply 220V 1 ph
- Integrated electro-hydraulic unit
- 360° Turnable table with interlocking

100%
made in
ITALY

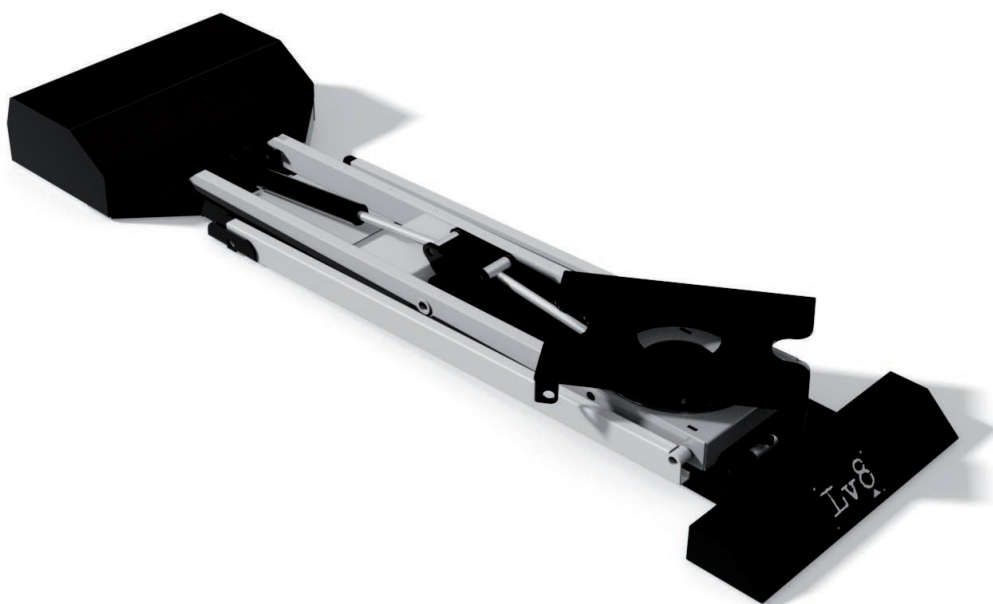

Modello Model	Portata Capacity	Con centralina elettrica With electro-hydraulic unit
Goldrake 500 ICKS	500Kg	X



EIE-LTPNK01 **OPTIONAL**

Kit radiocomando 2400MHZ
2400MHZ remote control kit



Rotante 360° con interblocchi
360° turnable with interlocking



Centralina elettroidraulica con
pulsantiera dotata di magnete
Electro-hydraulic unit with hand
control equipped with magnet



BETA.081880530 **OPTIONAL**

8188FG2 legatura fibbia 2
ganci e asole (3m)
8188FG2 cam buckle strap
with 2 s-hooks and eyes (3m)

CAPACITY
500KG

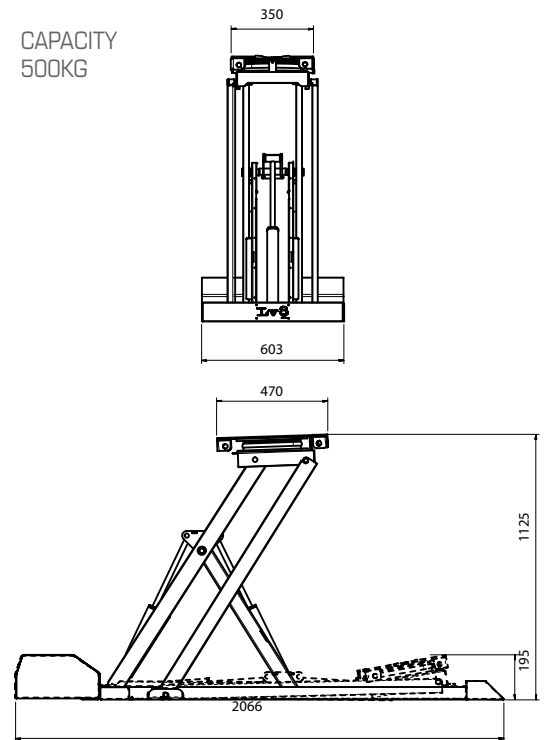

EG500XE

Con centralina elettroidraulica
With electro-hydraulic unit

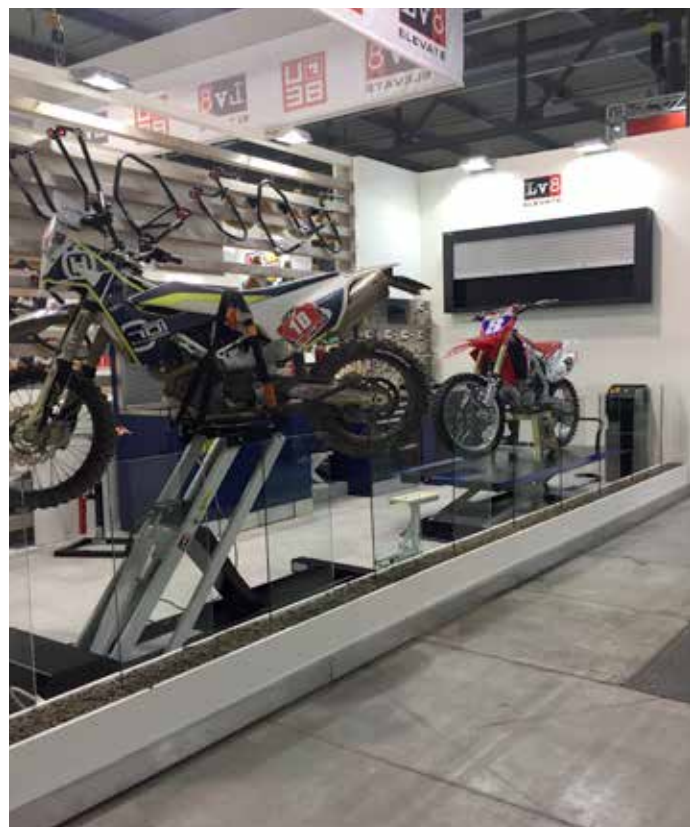

CUSTOMIZED MOTORCYCLE LIFTS

Ogni sollevatore moto può essere personalizzato secondo le specifiche del cliente o quelle imposte dalle case costruttrici rappresentate. Il nostro ufficio tecnico lavorerà al tuo fianco per amplificare la tua Corporate Identity.

Personalizzazioni cromatiche, grafiche e di intaglio laser rendono i nostri prodotti unici, sinonimo di artigianalità e di stile.

Every motorcycle lifter can be customized according to the customer's specifications or those imposed by the representing manufacturers. Our technical office will work on your side to enhance your Corporate Identity.

Personalized colors, graphics and laser engraving make our products unique, synonymous of craftsmanship and style.



ACCESSORIES

100%
made in
ITALY

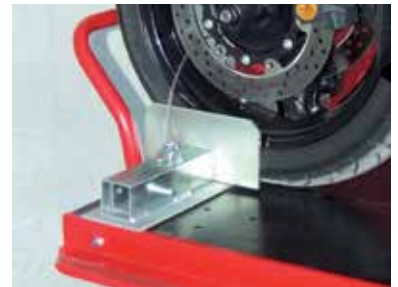
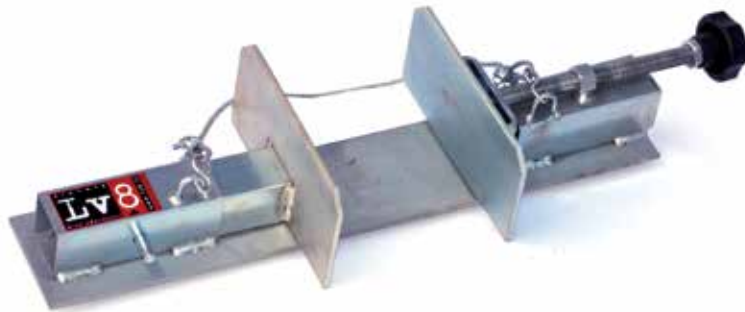

Fori per applicazione presenti solo su Goldrake Junior
Holes for applications are present only on Goldrake Junior

EWCS

Morsa manuale
Manual wheel clamp

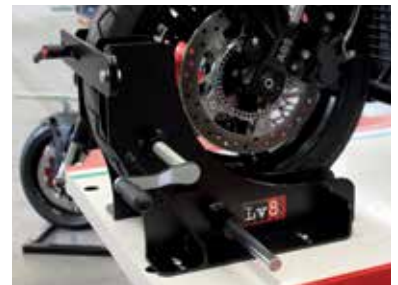

EWCM

Morsa meccanica
Mechanical wheel clamp

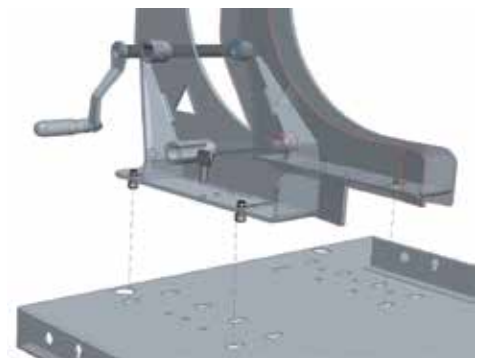

EWCM.QK

KIT sgancio rapido morsa manuale e pneumatica
QUICK FIX KIT for
mechanical and
pneumatic wheel clamp

EWCA.QK

KIT sgancio rapido morsa automatica
QUICK FIX KIT for
automatic wheel clamp



EWCA

Morsa automatica, ideale per sollevatori e anche per il trasporto delle moto nei camion, furgoni e rimorchi.
Automatic wheel clamp, ideal for lifts and for the motorcycle transportation in your truck, van or trailer as well.



EWCP

Morsa pneumatica
Pneumatic wheel clamp



EG350.17L

Rampa larga per Nano 350 (60x30cm)
Large ramp for Nano 350 (60x30cm)

EG500.17L

Rampa larga per Nano 500 (75x30cm)
Large ramp for Nano 500 (75x30cm)



EAP-ALL

Lamiera alluminio antiscivolo per Nano Garage,
Nano Track e Goldrake Moto (54x34cm)
Antiskid aluminium platform for Nano Garage,
Nano Track and Goldrake Moto (54x34cm)

EAP-ALLJ

Lamiera alluminio antiscivolo
per Goldrake Junior (50x31,5cm)
Antiskid aluminium platform for Goldrake Junior
(50x31,5cm)

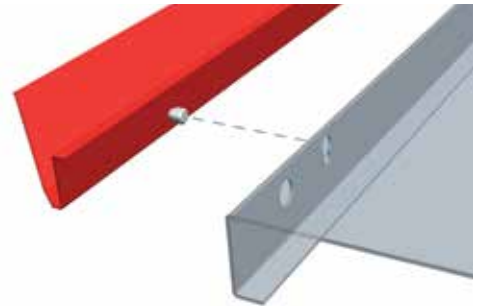

EG350.QK

Kit attacchi rapidi per alette porta utensili
Quick fix kit tool holders goldrake

EG600SE.QK

Kit attacchi rapidi estensioni laterali goldrake
Quick fix kit side extension goldrake

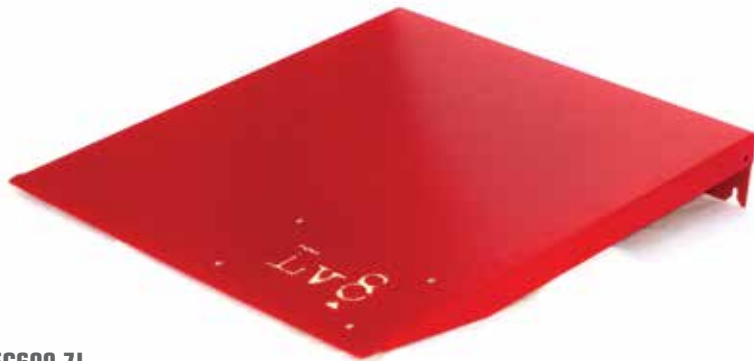

EG600.7L

Rampa larga per Goldrake Moto (75x80cm)
Large ramp for goldrake Moto (75x80cm)

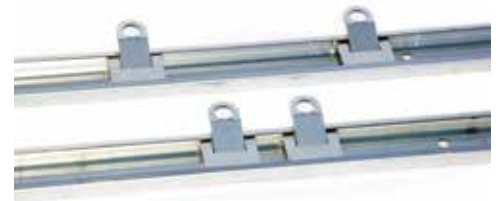

EG350TR

Guide per Goldrake 350Kg (210cm)
Tie rails for Goldrake 350Kg (210cm)

EG600TR

Guide per Goldrake 600Kg (210cm)
Tie rails for Goldrake 600Kg (210cm)

EG800TR

Guide per Goldrake 800Kg (220cm)
Tie rails for Goldrake 800Kg (220cm)

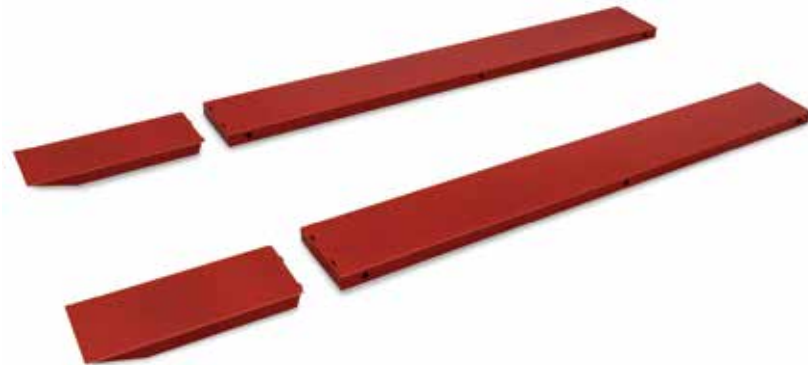

EG600SE

Kit di allargamento per Goldrake 600Kg
(210x27,5cm)
Side extensions kit for Goldrake 600Kg
(210x27,5cm)

EG800SE

Kit di allargamento per Goldrake 800Kg
(220x27,5cm)
Side extensions kit for Goldrake 800Kg
(220x27,5cm)

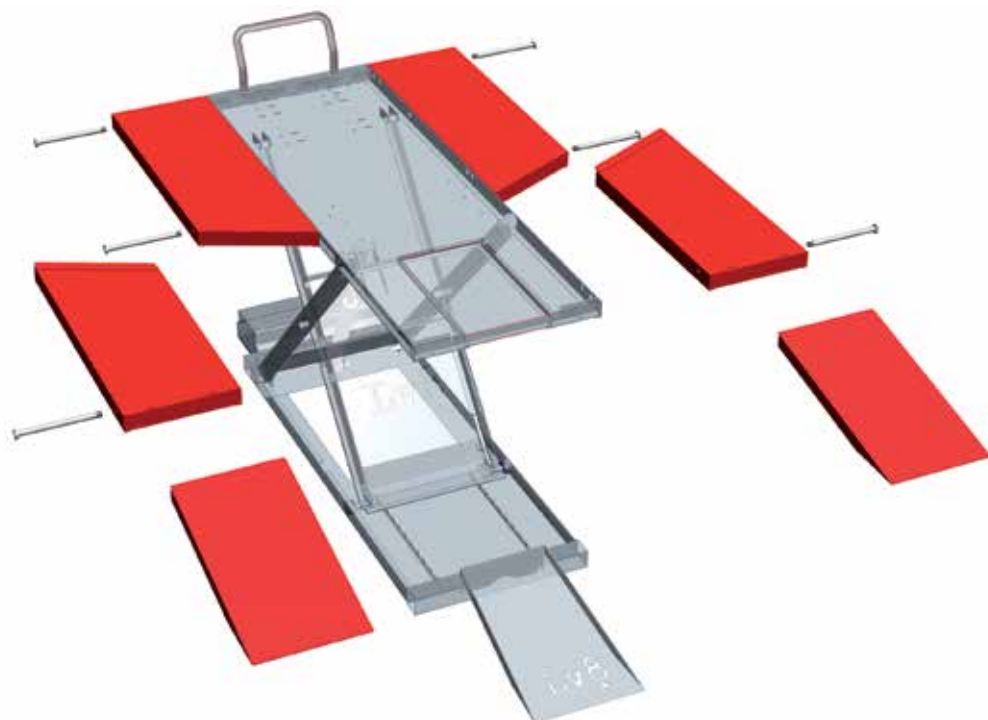

EG800SECA

Kit ali di allargamento scomponibili in due parti per veicoli a 3 ruote (CAN-AM). Utilizzabili su Goldrake 800. Dim. 2.200 x 425 mm
 Side extensions kit for 3 wheels vehicles (CAN-AM). Can be mounted on Goldrake 800 (no split version). Dim. 2.200 x 425 mm



EG800SET

Kit ali di allargamento per veicoli a 3 ruote (TRIKE). Utilizzabili su Goldrake 800. Dim. 2.200 x 315 mm
 Side extensions kit for 3 wheels vehicles (TRIKE). Can be mounted on Goldrake 800 (no split version). Dim. 2.200 x 315 mm



E500C

Cavalletto centrale a vite sotto culla per Custom, Harley Davidson, Enduro, Cross, Scooter
 Central Jack under cradle for Custom, Harley Davidson, Enduro, Cross, Scooter

Caratteristiche tecniche

- Altezza minima: 90mm
- Altezza massima: 310mm
- Capacità: 350kg
- Spostamento verticale del carico: 220mm
- Altezza colonne: 130mm
- Dimensioni ingombro: 510x210x170mm
- Peso: 18kg

Technical Features

- Minimum height: 90mm
- Maximum height: 310mm
- Capacity: 350kg
- Lifting height: 220mm
- Columns height: 130mm
- Dimensions: 510x210x170mm
- Weight: 18kg



E500C.L

Cavalletto centrale a vite sotto culla largo
 Large central Jack under cradle

Caratteristiche tecniche

- Altezza minima: 90mm
- Altezza massima: 370mm
- Capacità: 350kg
- Spostamento verticale del carico: 280mm
- Dimensioni ingombro: 510x300x90mm
- Peso: 28kg

Technical Features

- Minimum height: 90mm
- Maximum height: 370mm
- Capacity: 350kg
- Lifting height: 280mm
- Dimensions: 510x300x90mm
- Weight: 28kg



E500C.OPTION

Kit supporti regolabili optional, solo per E500C
 Optional adjustable supports kit, only for E500C



ERA20

Adattatori in gomma (140x120x20mm)
 Rubber adapters (140x120x20mm)



ERA40

Adattatori in gomma (160x120x40mm)
 Rubber adapters (160x120x40mm)



ERA60

Adattatori in gomma (160x120x60 mm)
 Rubber adapters (160x120x60 mm)



LV8



Beta

LV8



**ARREDO
FURNITURE**





www.lv8qube.it

SOLUZIONI DI ARREDO MODULARE PER
OFFICINA

MODULAR SYSTEMS FOR WORKSHOP
FURNITURE

Caratteristiche tecniche

Grazie ad un'ampia gamma di moduli è possibile strutturare e realizzare soluzioni personalizzate di arredo per officina.

Ogni modulo è stato progettato per soddisfare le necessità funzionali e le normative delle moderne officine moto. Il Vs. lavoro sarà più efficiente e produttivo grazie all'ergonomia e al sistema combinato e razionalizzato dell'arredo LV8 Qube.

Strutture robuste, maniglie in alluminio o in acciaio, tapparelle in alluminio, guide dei cassetti con cuscinetti e un'ampia gamma di accessori sono le principali caratteristiche di questa gamma di prodotti interamente progettata e realizzata in Italia.

I tecnici di LV8 sono a vostra disposizione per progettare e realizzare la vostra officina.

Technical Features

Thanks to a wide range of modules, it is possible to obtain personalised solutions for workshop furniture.

Every module has been designed to satisfy the practical needs and the regulations which apply to modern dealers' workshops.

You will be able to carry out your work in a more efficient and productive way thanks to the rationally combined LV8 Qube systems.

Robust frames, aluminium or steel handles, aluminium shutters, ball bearing drawer runners and a large selection of accessories are the main features of this product range which is designed and made entirely in Italy.

LV8 specialist staff are at your service to plan and fit your workshop.

100%
made in
ITALY





CATALOGO QUBE# 03
LV8 QUBE, l'arredo officina
Custom Tailor made

CATALOGUE QUBE #03
LV8 QUBE, workshop furniture
Custom Tailor made





 Lv8  Beta



 **PERTAMINA**

 **Beta Lv6**



CASSETTIERA SPECIALE RACING A 2 o 3 MODULI

Prodotto speciale costituito da 2 o 3 sotto-moduli, disponibili in 3 diversi modelli:

- Un MODULO A CASSETTIERA MOBILE con sette cassetti (simile al modello C39 ma con parete laterale liscia, senza portaflaconi integrato)
- Un MODULO DI SERVIZIO con un cestino portarifiuti, un vano per rotolo portacarta, un sistema aria compressa e due gruppi attacchi elettrici
- Un MODULO A DUE PORTE ANTERIORI

Ogni modulo è dotato di:

- Quattro rotelle orientabili provviste di un sistema di bloccaggio
- Logo Beta in rilievo sulla parte anteriore di ogni modulo

SPECIAL 2 or 3 MODULE RACING-TYPE CABINET

Special product composed of three fitted sub-modules, available in 3 different models:

- A 7 drawer ROLLER CAB MODULE (similar to C39 model but with a smooth side wall and without the integrated bottle-holder)
- A so called SERVICE MODULE including a garbage can, a hollow for a paper roll holder, a compressed air attack system and two electric sockets groups
- A TWO FRONT DOOR MODULE

Each module is equipped with:

- Four caster wheels provided with a locking system
 - Beta logo in relief on the module front side
- Same size for the three modules





MS29

Modulo di servizio
Service module

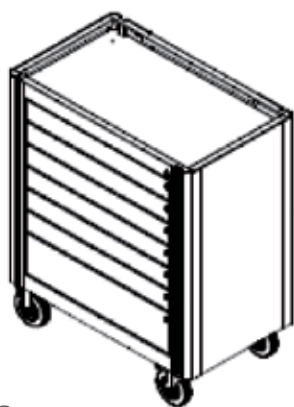

MC29

Modulo a cassetteria mobile
Roller cab module

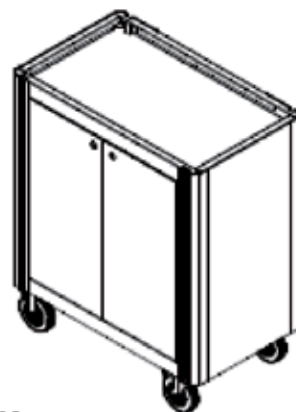

MD29

Modulo a due porte anteriori
Two front door module



W29 L.160 CM

Piano di lavoro in legno per 2 moduli
Wooden worktop for 2 modules



W29 L.240 CM

Piano di lavoro in legno per 3 moduli
Wooden worktop for 3 modules



Differenti colori a richiesta
Different colours on request



CANEPA

LV8 ELEVATE



**ATTREZZATURE E UTENSILERIA
GARAGE EQUIPMENT AND TOOLS**



WHEEL BALANCERS AND TYRE CHANGERS

100%
made in
ITALY



E0255

Equilibratrice elettronica - rosso std
Electronic wheel balancer - red std

Caratteristiche tecniche

Equilibratrice elettronica a display per ruote auto, furgoni e, tramite opportuni accessori opzionali, ruote moto. Dotata di lancio motorizzato attivabile tramite leva e di sistema manuale di frenatura e bloccaggio albero, la E0255 prevede l'inserimento manuale dei parametri di lancio (distanza, diametro, larghezza ruota). Concepita senza protezione ruota, garantisce un notevole risparmio di spazio all'interno dell'area di lavoro e risulta ideale per utilizzi in officine e stazioni di servizio o per interventi esterni su veicoli attrezzati.

Technical Features

Electronic wheel balancer for car, van and, using specific optional accessories, motorcycle wheels with motorized balancing cycle to be activated through an on-purpose lever. Equipped also with shaft braking and locking system, E0255 features a manual data entry system of spin parameters (distance, rim diameter, wheel width). Designed to be used without wheel cover, its reduced overall dimensions make this product ideal to be used as space saver in narrow repair shops or petrol stations or during mobile service activities.

Diametro massimo cerchio Max rim diameter	23"
Larghezza cerchio Rim width	1,5"-20"
Peso massimo ruota Max wheel weight	65 Kg (145(lbs))
Diametro albero Shaft diameter	40mm (1,6")
Velocità di rotazione Balancing speed	< 100 rpm
Precisione di equilibratura Balancing precision	± 1 gr (± 0,05 oz)
Tempo di ciclo Cycle time	9 sec
Livello di rumorosità Noise level	< 70 ± 3 dB(A)
Alimentazione Power supply	110/240V 1ph
Peso netto Net weight	50 Kg (110 lbs)



E0250

"Obelix" - smontagomme automatico - rosso std
 "Obelix" - automatic tyre changer - red std.

Caratteristiche tecniche

Smontagomme automatico con palo ribaltabile automatico e doppia velocità di rotazione dell'autocentrante. Disponibile nelle versioni 230V o 380V.

Technical Features

Automatic tyre changer with automatic tilting column and two speed chuck rotation. Available versions 230V or 380 V.



E0212

"Asterix" - smontagomme semi-automatico - nero opaco std.
 "Asterix" - semi-automatic tyre changer - mat black std.

Caratteristiche tecniche

Smontagomme semi-automatico con palo fisso e braccio a bandiera. Disponibile nelle versioni 230V o 380V.

Technical Features

Semi-automatic tyre changer with fixed column and swing arm. Available versions 230V or 380 V.

	E0250 Obelix	E0212 Asterix
Dimensioni Dimensions	mm 1590x1150x1770h	mm 940x1025x1825h
Peso netto Net weight	205 kg	150 kg
Diametro max ruota Max wheel diameter	1000 mm	1000 mm
Capacità di serraggio Clamping capacity	10" – 23"	5" – 23"
Largezza max ruota Max wheel width	320 mm (12,5")	320 mm (12,5")
Motore elettrico trifase 3-phase Electric motor	0,55KW (0,75HP)	0,55KW (0,75HP)
Motore elettrico monofase 1-phase Electric motor	0,75KW (1,0HP)	0,75KW (1,0HP)
Pressione esercizio circuito pneumatico Pressure of pneumatic circuit	8-10 BAR (116-145 PSI)	8-10 BAR (116-145 PSI)

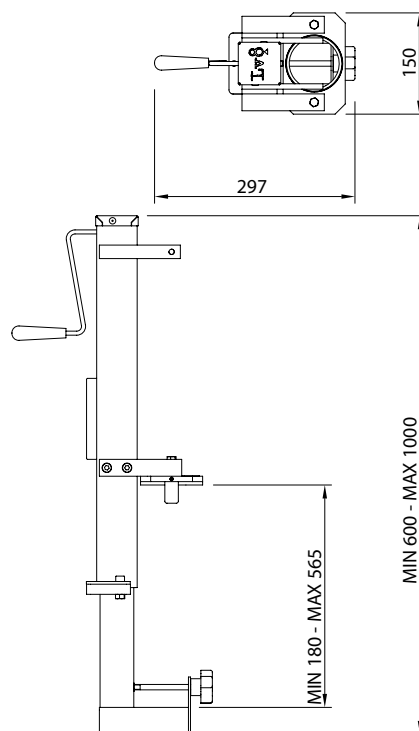

INCLUDED ADAPTER	74mm	E450SA.F74
E450SA-FK OPTIONAL ADAPTER KIT	45mm	E450SA.F45
	47mm	E450SA.F47
	50mm	E450SA.F50
	53mm	E450SA.F53
	56mm	E450SA.F56
	59mm	E450SA.F59
	62mm	E450SA.F62
	68mm	E450SA.F68
	71mm	E450SA.F71
	75mm	E450SA.F75
	77mm	E450SA.F77
	80mm	E450SA.F80
	84mm	E450SA.F84
87mm	E450SA.F87	



E450SA

Smonta molle per mono ammortizzatore e per forcelle, meccanico a vite
Shock-absorber disassembler, with mechanical screw compression system

WHEEL BALANCERS AND PRESSES

100%
made in
ITALY

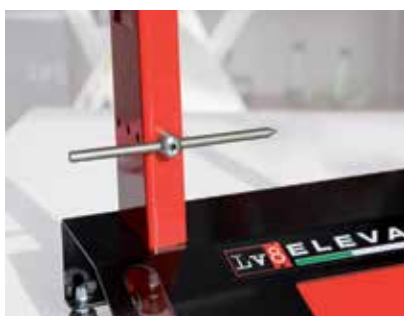

E9152KC

Kit asta centraggio cerchi
Rim centering kit



E9152A

Equilibratrice manuale
Static wheel balancer

Caratteristiche tecniche

Indispensabile per l'equilibratura delle ruote in officina o sui campi di gara. E' equipaggiata con cuscinetti volventi, livella di posizionamento e quattro piedini regolabili per ottenere la massima precisione. E' dotata di una coppia di coni che si adattano a qualsiasi tipo di mozzo.

Technical Features

Suitable for wheel balancing in the workshop or on racing tracks. This static wheels balancer is supplied with a rod and two locking cones that fit any kind of hub. The rod works on special bearings that allow the wheel to rotate smoothly for precise adjustment. It is equipped with a rebbet level and four adjustable feet to get the proper perpendicular and the most precise parallelism to the base.



E9152K-K1290

Kit adattatori per KTM
1290 Super Duke R
Adapters kit for KTM
1290 Super Duke R



E9152KB

Kit adattatori per BMW
Adapters kit for BMW



E9152KM

Kit adattatori per ruote
monobraccio
Adapters kit for single-arm
wheels



E9152KS

Kit adattatori per scooters e
maxi scooters
Adapters kit for scooters and
maxi scooters



E9152KS2

Kit adattatori per scooter
PIAGGIO MP3
Adapters kit for scooter
PIAGGIO MP3



EPR10BPM
(10 ton)

EPR15BPM
(15 ton)

Pressa idraulica da banco con pistone mobile
Hydraulic workbench press with movable piston

Caratteristiche tecniche Technical Features

- Pompa a mano a due velocità Double-speed hand pump
- Sicurezza idraulica in caso di sovraccarico Overload safety-valve
- Ritorno automatico del pistone Automatic return of the ram
- Stelo cromato Chromium plated rod
- Manometro Pressure gauge
- Serie di prismi a V V-blocks



EPR10PM
(10 ton)

EPR20PM
(20 ton)

Pressa idraulica a colonna con pistone mobile
Hydraulic press with movable piston

Caratteristiche tecniche Technical Features

- Pompa a mano a due velocità Double-speed hand pump
- Sicurezza idraulica in caso di sovraccarico Overload safety-valve
- Ritorno automatico del pistone Automatic return of the ram
- Stelo cromato Chromium plated rod
- Manometro Pressure gauge
- Serie di prismi a V V-blocks



EPR-OPTION2

Kit piastra cacciaspine e punzoni
Per pressa 10 ton
Press plate + punch set
For press 10 ton



EPR-OPTION3

Kit piastra cacciaspine e punzoni
Per pressa 15 ton
Press plate + punch set
For press 15 ton

EPR-OPTION4

Kit piastra cacciaspine e punzoni
Per pressa 20 ton
Press plate + punch set
For press 20 ton



EPR-OPTION1

Comando a pedale (optional)
Pedal drive (optional)

CRANES, TANKS AND WASHING TRAYS

100%
made in
ITALY



ECR-500

Gru idraulica pieghevole con pompa a doppio effetto (capacità: 500kg)
Hydraulic folding crane with double action pump (capacity: 500kg)



ECR-1000

Gru idraulica pieghevole con pompa a doppio effetto (capacità: 1000kg)
Hydraulic folding crane with double action pump (capacity: 1000kg)



ECOT.10

Ecotanica 10lt
Ecotank 10lt



ECOT.12P

Ecotanica 12lt
Ecotank 12lt

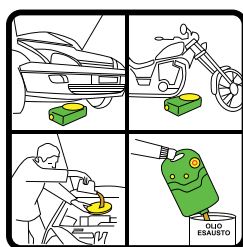
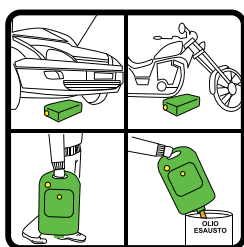

	ECOT.10	ECOT.12P
Capacità Capacity	10lt	12lt
Dimensioni Dimensions	57x32,5x12,5cm	57x37x13,5cm
Peso Weight	0,8Kg	1,5Kg
Colori Colours	Verde Green	Verde+giallo Green+yellow



EG50026

Vasca di lavaggio Compact
Compact washing tray

Technical Features

- No VOCs, biodegradable, no waste disposal needed, non flammable
- the cleaner continuously renews itself
- Cleans parts efficiently and most of all safely
- Easy-to-use
- Automatic controls

Materials

- compatible with all materials (metals, rubbers, pvc, electrical parts, painted parts)
- All surfaces

IT IS THE MOST SAFE AND EFFECTIVE ALTERNATIVE TO HAZARDOUS SOLVENTS IN WASHING APPLICATIONS, ELIMINATING THE HAZARD FOR HEALTH AND SAFETY AND REMOVING THE WASTE DISPOSAL REQUIREMENT.

	EG50026
Dimensioni Dimensions	74x54x104h
Temperatura di esercizio Operating temperature	41°
Capacità max Max capacity	90 kg
Capacità di carico Load capacity	100 lt
Configurazione elettrica Electrical configuration	230 V



E0719.E

Vasca lavaggio elettrica
Electric washing tray

	E0719.E
Dimensioni Dimensions	75,5x52,5x87,5h cm
Capacità Capacity	65 Lt
Configurazione elettrica Electrical configuration	230 V

TECHNICAL TANKS

100%
made in
ITALY



E1681

Gonfiagomme 10 Lt
Tyre inflating device 10 Lt



E2081

Recuperatore olio esausto per motocicli 45 Lt
Exhausted oil recuperator for motorcycles 45 Lt



E0291

Nebulizzatore 24 Lt
Sprinkler 24 Lt

CHASSIS DYNAMOMETER

100%
made in
ITALY



EBPM

Banco prova potenza / simulatore di strada motocicli Chassis dynamometer / road simulator for motorbikes

Caratteristiche tecniche

- Freno a correnti parassite
- Simulazione delle condizioni stradali (salite, resistenza aerodinamica, peso)
- Prove a regimi e velocità costanti
- Diagnosi con qualsiasi strumento riproducendo qualsiasi condizione di carico e velocità
- Prove di durata e collaudi
- Misurazione precisa e ripetibile della potenza
- Verifica trasmissioni (slittamento frizione)
- Funzione Datalogger con possibilità di confronto delle prove (prima e dopo la modifica/riparazione)
- Controllo tramite telecomando IR dal veicolo

Configurazione standard

- Versione incassata o rialzata
- Rulli godronati sull'intera larghezza
- Trasmisione con cinghia HTD tra i rulli
- Stazione meteorologica
- Telecomando a raggi infrarossi

Technical Features

- Eddy current brake
- Road condition simulation (slopes, aerodynamic resistance, weight)
- Testing at constant speeds and engine speeds
- Diagnosis with any equipment, reproducing any load and speed condition
- Endurance and inspection tests
- Precise and repeatable power measurement
- Transmission check (clutch slipping)
- Datalogger function with possibility of comparing tests (before and after modification/repair)
- Control through IR remote control from vehicle

Standard configuration

- In ground or above ground versions
- Knurled rollers along entire width
- Transmission with HTD belt between rollers
- Weather station
- Infrared remote control

	EBPM-1R	EBPM-2R
N. di Rulli N. of Rollers	1	2
Diametro rulli Roller Diameter	400 mm	400 mm
Larghezza rulli Roller Width	310 mm	310 mm
Altezza Height	410 mm	410 mm
Massa Weight	510 kg	600 kg
Velocità massima Maximum Speed	350 km/h	350 km/h
Potenza massima Maximum Power	200 CV	500 CV
Forza di trazione massima Maximum Traction Force	5000 N	5000 N



EBPC

**Cabina Fonoisolante
per sala prova banco EBPM-1R / EBPM-2R**

Costruita con pannelli modulari fonoassorbenti in classe 0 di spessore 50 mm. Le dimensioni esterne sono pari a 3000 x 4000 mm (larghezza x lunghezza) con un'altezza utile interna pari 2500 mm. Dotata di porta a doppio battente con guarnizioni di tenuta con dimensioni 2000 x 2500 mm (larghezza x altezza). La porta è dotata di 1 visiva in vetro di sicurezza 5 + 5 (o superiore). L'entrata aria esterna è silenziata per mezzo di un silenziatore a setti. I ventilatori di estrazione sono posizionati sulla copertura nella parte posteriore. Sono dotati di griglie di protezione. Ai ventilatori è accoppiato un silenziatore, il quale impedirà la fuga di rumore attraverso le luci di espulsione aria. La sala prova è dotata di sorgenti luminose mediante plafoniere con tubi al neon distribuite nella sala per raggiungere il miglior confort visivo. Il tutto è cablato con materiale antifiama.

**Sound-insulated cabin
for test-bench EBPM-1R/2R**

with total external dimension 3000x4000.
The structure is made up of steel beams onto which panels are fixed. The panels contain a substantial layer of material with high level of soundproofing/sound absorption with certified reduction coefficient. The double doors have a dimension of 2000x2500. The cabin is equipped with a suitably sized ventilation system to allow correct internal air exchange. The ventilation system, like the exhaust gas intake system, is suitably silenced through silencers with sound absorbing partitions in order to insulate all possible noise. The cabin is a turn-key product; supply includes electrical system, lighting and electrical control panel.



MOTO RACE TOOLS KIT



EUT-MRK-C1

Wrenches set 29 UT
Assortimento chiavi combinate e a
forchetta 29 UT



EUT-MRK-C2

Screwdrivers set 21 UT
Assortimento cacciaviti e chiavi a nasello
21 UT



EUT-MRK-C3

Pliers set 17 UT
Assortimento pinze 17 UT



EUT-MRK-C15

Torque wrenches and multi-sockets set 43 UT
Assortimento chiave dinamometrica, bussole esagonali e
accessori 43 UT



EUT-MRK-C13

T-handle wrenches set 29 UT
 Assortimento chiavi esagonali a T, Torx e
 cacciaspine 29 UT



EUT-MRK-C16

Special tools set 15 UT
 Assortimento utensili speciali 15 UT



EUT-MRK-C17

Long screwdrivers and hammers set 15 UT
 Assortimento cacciaviti lunghi, martelli e lime 15 UT



EUT-MRK-C8

T-handle wrenches with swivelling hexagon sockets set 9 UT
 Assortimento buttole esagonali a T snodate 9 UT



EUT-MRK-C7

Big torque wrench and long screwdrivers
set 29 UT
Assortimento chiave dinamometrica
grande e cacciaviti lunghi 29 UT



EUT-MRK-C10

Special pliers set 10 UT
Assortimento pinze speciali 10 UT



EUT-MRK-C9

Measuring tools set 10 UT
Assortimento utensili di misura 10 UT



EUT-MRK-C11

Electric tools set 7 UT
Assortimento utensili elettrici 7 UT



1474L

Pinza per cappucci candele d'accensione a becchi lunghi piegati 15°
Spark-plug pliers, curved long nose, 15°



1493Z/1

Chiave autoserrante per filtri olio Ø 60÷80 mm
Self-locking oil filter wrenches Ø 60÷80 mm



1532

Utensile per rimozione guarnizioni
Packing removal tool



1568/C15

Kit per ribaditura e smagliature catene
Chain riveting and opening kit
Misure Sizes: 3-4-5mm + kit Regina



1767PMR

Portaminuterie magnetico rettangolare
Rectangular magnetic tool holder



1838/11LED

lampada ricaricabile con LED ad altissima luminosità, batteria ai polimeri di litio
Rechargeable inspection lamp with ultra-high brightness LEDs Lithium polymer battery



1599/125

Morsa da banco braun mm.125
Braun bench vice mm.125



1599G

Copie di copriganasce in alluminio mm. 125
Pairs of aluminium jaw covers mm. 125



1949DGT

Pistola digitale per gonfiaggio pneumatici
Digital tyre inflator



437U/09

Kit di ripristino delle filettature danneggiate
Repairing damaged threads kit



1481PL/S3

Set 3 pinze in plastic per occlusione tubi
Set of 3 plastic hose pliers



1737

Spazzolino in ottone
Brush, brass wires



1439/K7

Cassetta giravite angolare 90° tipo lungo
con lame
Angular screwdriver (90°), long series, with
blades, in case



1410/M

Atrezzo ad uncino per trazione molle
Spring pulling hook wrench



1467

Strumento estrazione liquido freni
Brake fluid extractor



950/S9

Set chiavi a T con bussola esagonale
Set of T-handle hexagon socket wrenches
Misure Sizes: 7-8-10-11-12-13-14-17-19



96BPC/SC9

Set brugole lunghe con estremità sferica
Set of ball head offset hexagon key wrenches
Misure Sizes: 1,5-2-2,5-3-4-5-6-8-10



1712E/L1

Flessibile magnetico con illuminazione a led
Flexible magnetic pick-up tool with LED light

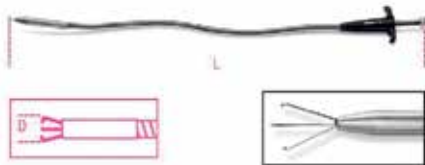

1713M

Artigli pensile flessibili
Flexible pickup tools
Misure Sizes: 500 mm



1720/B6

Set lime ad ago
Set of needle files



99SQ

Chiave a settore con nasello quadro per ghiera
Hook wrenches with square noses for ring nuts
Misure Sizes: 50-80 mm



1771BM

Cutter 18 mm, 3 lame
Utility knife, 18 mm, 3 spare blades



1761

Pinza torcifilo
Locking wire pliers



31/B6

Set 6 pz caccia spine in busta
Set of 6 pin punches in wallet





**IMPIANTISTICA
PLANT DESIGN**



EXHAUST GAS



EIG-GMR757

Arrotolatore completo di tubo antischiaciamento (Ø 75 mm / L. 7,5 mt)
Recoil hose reel complete with crushproof flexible hose (Ø 75 mm / L. 7,5 mt)



EIG-GMRF757

Arrotolatore con aspiratore completo di tubo antischiaciamento (Ø 75 mm / L. 7,5 mt)
Recoil hose reel complete with fun and crushproof hose (Ø 75 mm / L. 7,5 mt)



EIG-GRK1758 **EIG-GRK17512**
length: 8mt length: 12mt

Canalina in alluminio completa di aspiratore 1 HP, un carrello scorrevole con tubo e bocchetta
Aluminium track complete with fun 1 HP, one carriage with hose and nozzle



EIG-GRK2758 **EIG-GRK27512** **EIG-GRK27516**
length: 8mt length: 12mt length: 16mt

Canalina in alluminio completa di aspiratore 1,5 HP, due carrelli scorrevoli con tubo e bocchette.
Aluminium track complete with fun 1,5 HP, two carriages with hose and nozzles

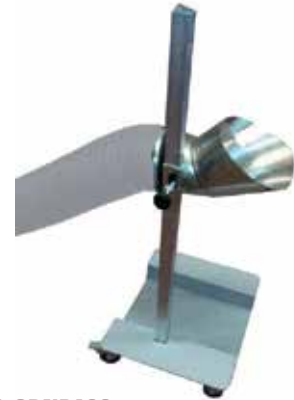

EIG-GRNP100

Bocchetta Ø 200 in acciaio inox montata su carrello con asta di regolazione
Trolley mounted stainless steel nozzle Ø 200 with adjusting rod



EIG-GY757575

Deviazione a Y con due spezzoni di tubo (Ø 75 L. 1,25 mt) e bocchette Ø 160
Adaptor with 2 hose pieces (Ø 75 L. 1,25 mt) and nozzles Ø 160



EIG-B200

Bocchetta in gomma Ø 200
Rubber nozzle Ø 200



EIG-GRNT16075

Bocchetta in gomma Ø 160 con tappo rimovibile in silicone
Rubber nozzle Ø 160 with silicon removable cap



EIG-GSR

Sgancio rapido per sostituzione bocchetta
Quick coupling for flexible hose suitable for
nozzle replacement



EIG-GSA0.5 EIG-GSA1 EIG-GSA1.5 EIG-GSA2
0,5 HP 1 HP 1,5 Hp 2 HP
0,35 Kw 0,75 Kw 1,1 Kw 1,5 Kw

Elettroaspiratore completo di supporto di
fissaggio
Sheet steel fan with fixing support



EIG-GT2752 EIG-GT2755 EIG-GT2757
Ø 75 Ø 75 Ø 75
L. 2,5 mt L. 5 mt L. 7,5 mt

Tubo antisciacchiamento per temperatura
max 200°C
Crushproof hose for max. temperature
200°C



EIG-GT51002 EIG-GT51005
Ø 100 Ø 100
L. 2,5 mt L. 5 mt

Tubo per temperatura max 500°C
Hose for max. temperature 500°C



EIG-GMS1755 EIG-GMS1757
length: 5 mt length: 7 mt

Kit fisso a parete con aspiratore e un tubo
flessibile
Wall mounted exhaust extraction kit with fan
and hose



EIG-GMS2755 EIG-GMS2757
length: 5 mt length: 7 mt

Kit fisso a parete con aspiratore e due tubi
flessibili
Wall mounted exhaust extraction kit with
fan and two hoses

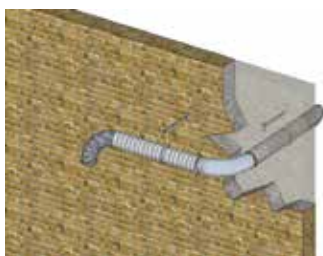

EIG-ZGS125KC1 EIG-ZGS160KC1 EIG-ZGS200KC1
Ø 125 Ø 160 Ø 200

Kit tubi camino per espulsione laterale
(L. 3 mt)
Chimney hoses kit for lateral exhaust
expulsion (L. 3 mt)

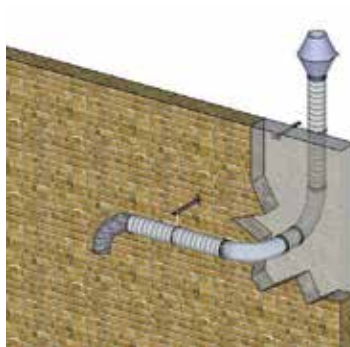

EIG-ZGS125KC2 EIG-ZGS160KC2 EIG-ZGS200KC2
Ø 125 Ø 160 Ø 200

Kit tubi camino per espulsione verticale
(L. 7 mt)
Chimney hoses kit for vertical exhaust
expulsion (L. 7 mt)

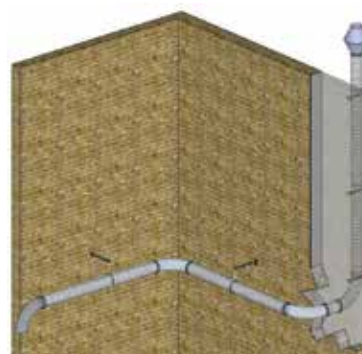

EIG-ZGS125KC3 EIG-ZGS160KC3 EIG-ZGS200KC3
Ø 125 Ø 160 Ø 200

Kit tubi camino per espulsione verticale
(L. 10 mt)
Chimney hoses kit for vertical exhaust
expulsion (L. 10 mt)

FLUID EXTRACTION



EI-KPM

Kit singolo a parete per la distribuzione olio / versione con pompa murale
Single-wall kit for oil distribution / wall pump version



EI-KPF

Kit singolo a parete per la distribuzione olio / versione con pompa per fusto
Single-wall kit for oil distribution / pump for drums version

Codice code	Portata Capacity	Lunghezza tubo hose lenght
EI-KPM31.10	3:1	10 mt
EI-KPM51.10	5:1	10 mt
EI-KPF31.10	3:1	10 mt
EI-KPF51.10	5:1	10 mt



EI-PF60.202

Pompa manuale con pescante telescopico per fusti 60-202 Lt
Manual pump for drums with telescopic suction tube 60-202 Lt

Codice code	Dimensioni dimensions	N° fusti Drums n°
EIO-EKON101Z	800x800x450	1
EIO-EKON102Z	1200x800x340	2
EIO-EKON104Z	1200x1200x300	4



EIO-EKON101Z

Vasca portafusti (1 fusto)
Drums container (1 drum)

EIO-EKON102Z

Vasca portafusti (2 fusti)
Drums container (2 drums)

EIO-EKON104Z

Vasca portafusti (4 fusti)
Drums container (4 drums)



EIO-ECOIL260N

Campana per raccolta e stoccaggio olio esausto 300 lt
Exhaust oil recovery and stocking tank 300 lt

EIO-ECOIL500N

Campana per raccolta e stoccaggio olio esausto 500 lt
Exhaust oil recovery and stocking tank 500 lt



EIG-CBE600ADRCT

Vasca per raccolta batterie esauste 250 LT - Coperchio optional
Battery container to stock empty battery 250 Lt - Optional cover



MOTO
PLEX



PIAGGIO®



ELEVATE

Via Peppone e Don Camillo, 11 - Z.I. Dugara
CAP 42041 - Brescello (Reggio Emilia) - ITALY
Ph. +39 0522 687907
Fax +39 0522 684498
www.lv8elevate.it - info@lv8.it

www.lv8elevate.it



ELEVATE

Via Peppone e Don Camillo, 11 - Z.I. Dugara
CAP 42041 - Brescello (Reggio Emilia) - ITALY
Ph. +39 0522 687907
Fax +39 0522 684498
www.lv8elevate.it - info@lv8.it

www.lv8elevate.it

Tutti i diritti riservati. Ogni riproduzione, anche parziale, del presente catalogo è vietata senza previa autorizzazione scritta. Il produttore si riserva il diritto di modificare od implementare la gamma dei prodotti a catalogo in qualsiasi momento e senza preavviso.

All rights reserved. Any reproduction, even partial, of the present catalogue is not allowed without any previous written authorization. The Manufacturer reserves the right to change or implement the range of the products in this catalogue at any time and without previous notice.